

Fan Packages

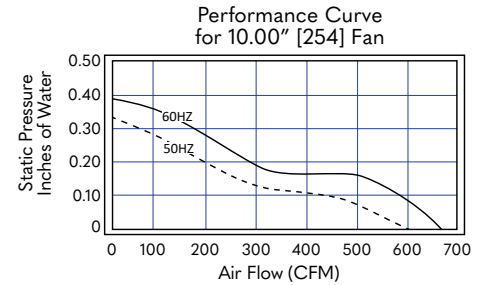
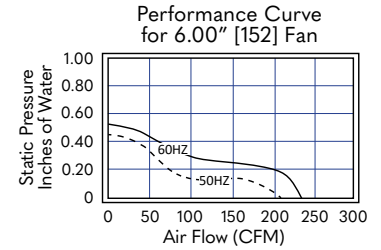
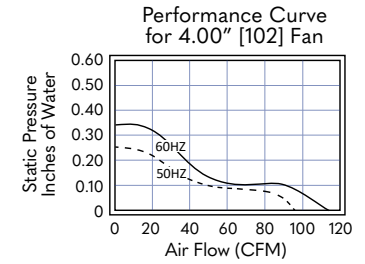
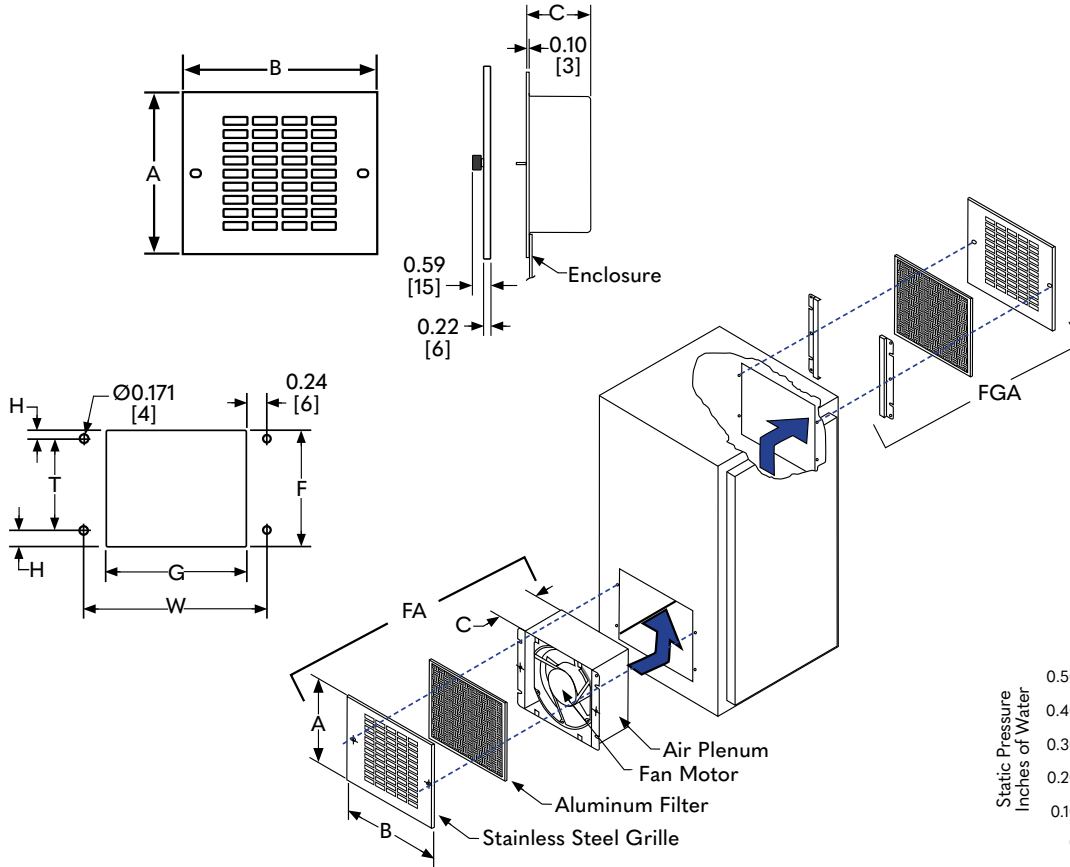

Fan Packages (Includes Fan, Grille, and Filter)

Catalog Number	CFM 50/60 Hz	Watts	Voltage	Hz	Line Amps	Motor RPM	Service Temp °F (°C)	Noise SIL (dB)	Weight lb. (kg)
SCE-FA44	63/75	23/20	115V	50/60	0.19	2600/3000	140(60)	41/44dB	4.20(1.90)
SCE-FA66	135/158	34/30	115V	50/60	0.25	2700/3000	140(60)	51/55dB	5.30(2.40)
SCE-FA1010	400/440	37/33	115V	50/60	0.29	1400/1650	140(60)	52/55dB	12.00(5.40)
SCE-FA44-230	63/75	23/20	230V	50/60	0.09	2600/3000	140(60)	41/44dB	4.20(1.90)
SCE-FA66-230	135/158	32/28	230V	50/60	0.12	2700/3000	140(60)	51/55dB	5.30(2.40)
SCE-FA1010-230	400/440	37/33	230V	50/60	0.14	1400/1650	140(60)	52/55dB	12.00(5.40)
SCE-FA66-24VDC	155	24	24VDC		0.98	3300	140(60)	52dB	5.30(2.40)
SCE-FA1010-24VDC	425	24	24VDC		0.97	2000	140(60)	47dB	12.00(5.40)
SCE-FA44-24VDC	105	5	24VDC		0.18	2300	140(60)	38dB	2.6(1.20)

Life Expectancy - 70,000 Hours minimum @ 25°C
 Operating Temperature -10°C ~ +65°C / 66%

Exhaust Grille and Filter Packages

Catalog Number	Grille Size	Filter Size	Cutout F x G
SCE-FGA44	6.11 x 7.38 [155] x [187]	5.42 Square	5.66 x 5.91 [144] x [150]
SCE-CF6	7.61 x 8.88 [193] x [225]	6.92 Square	7.16 x 7.41 [182] x [188]
SCE-CF10	11.62 x 13.00 [295] x [330]	10.92 Square	11.16 x 11.41 [283] x [290]

Dimensions for Cutout

Catalog Number	Dimensions A x B x C	F	G	H	T	W
SCE-FA44 SCE-FGA44	6.11 x 7.38 x 2.38 [155] x [187] x [83]	5.66 [144]	5.91 [150]	0.77 [20]	4.12 [105]	6.38 [162]
SCE-FA66 SCE-FGA66	7.61 x 8.88 x 3.06 [193] x [225] x [95]	7.16 [182]	7.41 [188]	1.33 [34]	4.50 [114]	7.88 [200]
SCE-FA1010 SCE-FGA1010	11.62 x 13.00 x 4.56 [295] x [330] x [133]	11.16 [283]	11.41 [290]	2.14 [54]	6.88 [175]	11.88 [302]