

# EYE BOLT CAPACITY

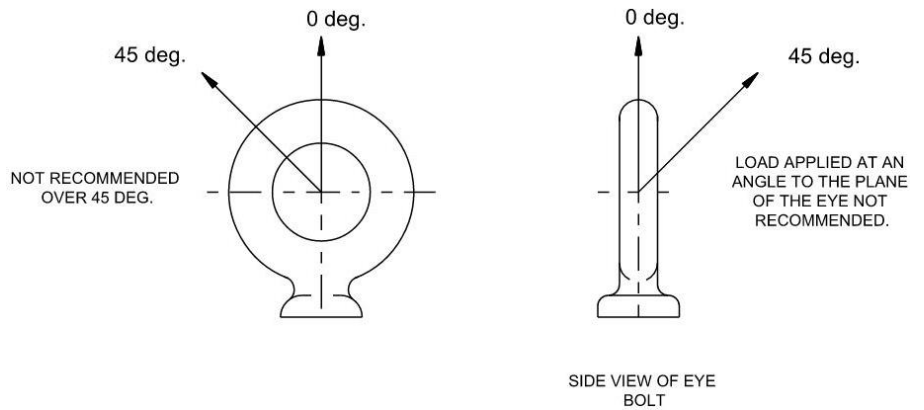

## WARNING!

RATED CAPACITY IS SUBSTANTIALLY REDUCED WHEN LOADING AT ANY ANGLE. LOADING MUST NEVER BE MADE AT AN ANGLE GREATER THEN 45° FROM BOLT CENTERLINE. AT AN ANGLE OF 45° RATED CAPACITY IS REDUCED RATED CAPACITY IS SUBSTANTIALLY REDUCED



A	B	C	D	E	F	G	LIFT CAPACITY PER EYEBOLT	
							0°	45°
0.50-13	1.25	1.22	2.11	0.91	0.22	1.33	1300	325
0.63-11	1.25	1.38	2.58	1.03	0.25	1.63	1600	400
0.75-10	1.25	1.50	2.82	1.19	0.25	1.67	3000	750

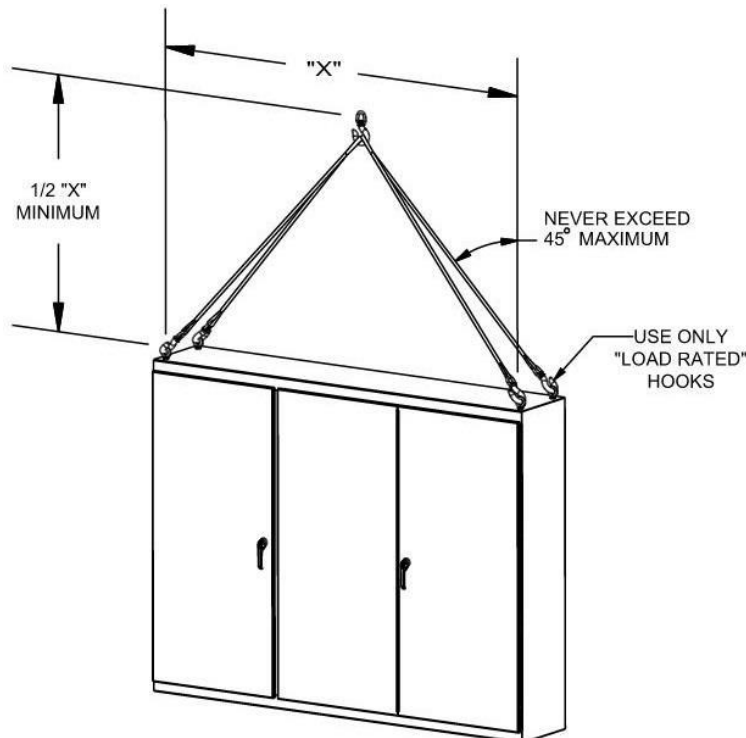

## EYEBOLTS SHOULDER PATTERN

