

# DRIP SHIELD KIT

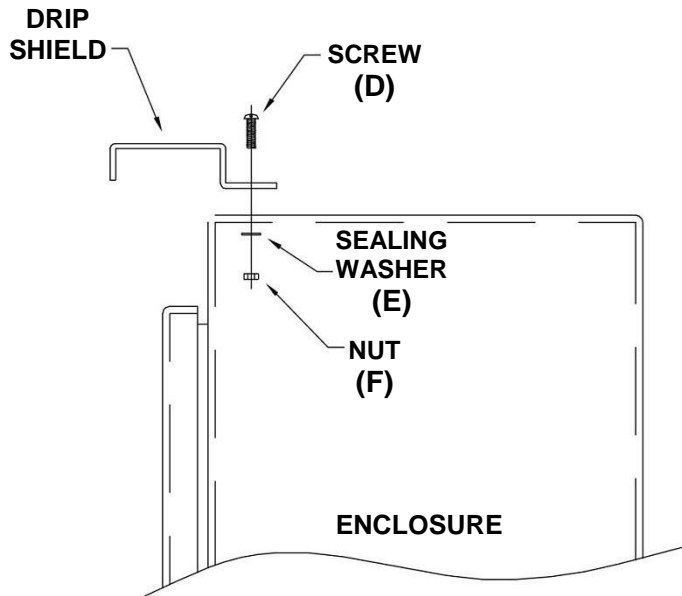
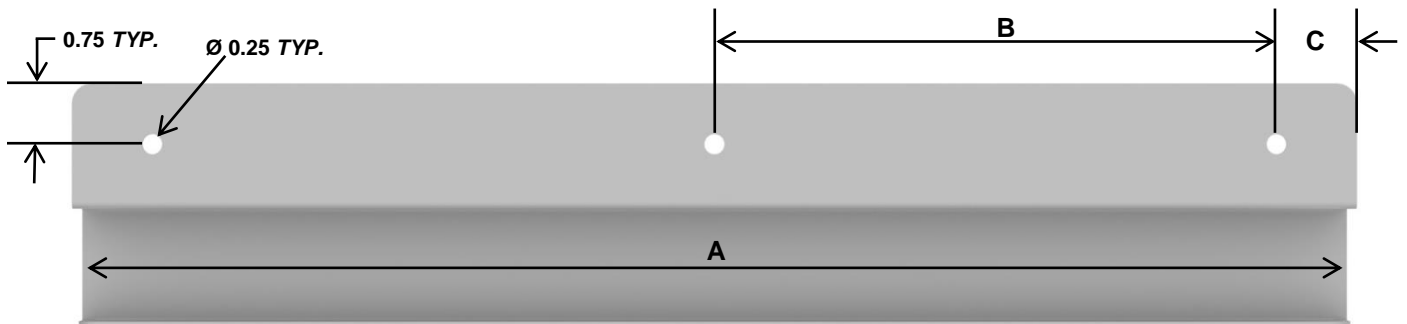

## **BOLT PACK # 109427 INCLUDED**

**D=** SS, 10-32 x 0.50 PAN  
HEAD PHILLIPS SCREW

**E=** STEEL, SEALING  
WASHER FOR 10-32

**F=** STEEL, 10-32  
SERRATED FLANGE  
NUTS

**INSTALL VARIATION 1**

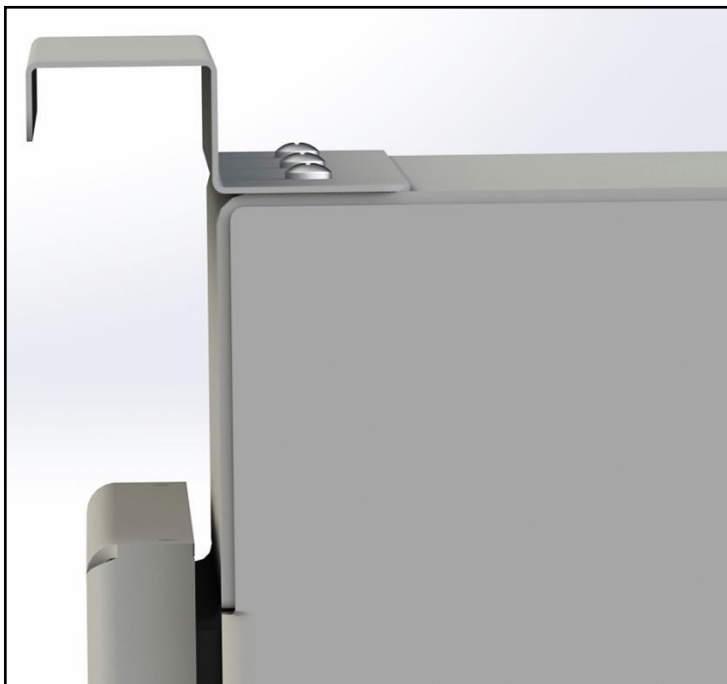

**INSTALL VARIATION 2**



# DRIP SHIELD KIT

DRIP SHIELD KIT FOR TYPE 12 & 4 ENCLOSURES- ANSI 61 GRAY							
PART #	A	B	C	# HOLES	D	E	F
SCE-DS12N4	12.00	10.00	1.00	2	2	2	2
SCE-DS16N4	16.00	7.00	1.00	3	3	3	3
SCE-DS20N4	20.00	9.00	1.00	3	3	3	3
SCE-DS24N4	24.00	7.25	4.75	3	3	3	3
SCE-DS30N4	30.00	6.83	4.75	4	4	4	4
SCE-DS36N4	36.00	8.83	4.75	4	4	4	4
SCE-DS42N4	42.00	8.13	4.75	5	5	5	5
SCE-DS48N4	48.00	9.63	4.75	5	5	5	5
SCE-DS60N4	60.00	10.10	4.75	6	6	6	6
SCE-DS72N4	72.00	8.93	4.75	8	8	8	8

DRIP SHIELD KIT FOR TYPE 12 & 4 ENCLOSURES- RAL 7035 GRAY							
PART #	A	B	C	# HOLES	D	E	F
SCE-DS12N4LG	12.00	10.00	1.00	2	2	2	2
SCE-DS16N4LG	16.00	7.00	1.00	3	3	3	3
SCE-DS20N4LG	20.00	9.00	1.00	3	3	3	3
SCE-DS24N4LG	24.00	7.25	4.75	3	3	3	3
SCE-DS30N4LG	30.00	6.83	4.75	4	4	4	4
SCE-DS36N4LG	36.00	8.83	4.75	4	4	4	4

DRIP SHIELD KIT FOR TYPE 4X ENCLOSURES- SS							
PART #	A	B	C	# HOLES	D	E	F
SCE-DS12SS	12.00	10.00	1.00	2	2	2	2
SCE-DS16SS	16.00	7.00	1.00	3	3	3	3
SCE-DS20SS	20.00	9.00	1.00	3	3	3	3
SCE-DS24SS	24.00	7.25	4.75	3	3	3	3
SCE-DS30SS	30.00	6.83	4.75	4	4	4	4
SCE-DS36SS	36.00	8.83	4.75	4	4	4	4
SCE-DS42SS	42.00	8.13	4.75	5	5	5	5
SCE-DS48SS	48.00	9.63	4.75	5	5	5	5
SCE-DS60SS	60.00	10.10	4.75	6	6	6	6
SCE-DS72SS	72.00	8.93	4.75	8	8	8	8

DRIP SHIELD KIT FOR TYPE 4X ENCLOSURES- SS6							
PART #	A	B	C	# HOLES	D	E	F
SCE-DS12SS6	12.00	10.00	1.00	2	2	2	2
SCE-DS16SS6	16.00	7.00	1.00	3	3	3	3
SCE-DS20SS6	20.00	9.00	1.00	3	3	3	3
SCE-DS24SS6	24.00	7.25	4.75	3	3	3	3
SCE-DS30SS6	30.00	6.83	4.75	4	4	4	4
SCE-DS36SS6	36.00	8.83	4.75	4	4	4	4
SCE-DS42SS6	42.00	8.13	4.75	5	5	5	5
SCE-DS48SS6	48.00	9.63	4.75	5	5	5	5
SCE-DS60SS6	60.00	10.10	4.75	6	6	6	6
SCE-DS72SS6	72.00	8.93	4.75	8	8	8	8