

SAGINAW CONTROL & ENGINEERING DEAD FRONT, WALLMOUNT EL-LPPL, INSTALLATION

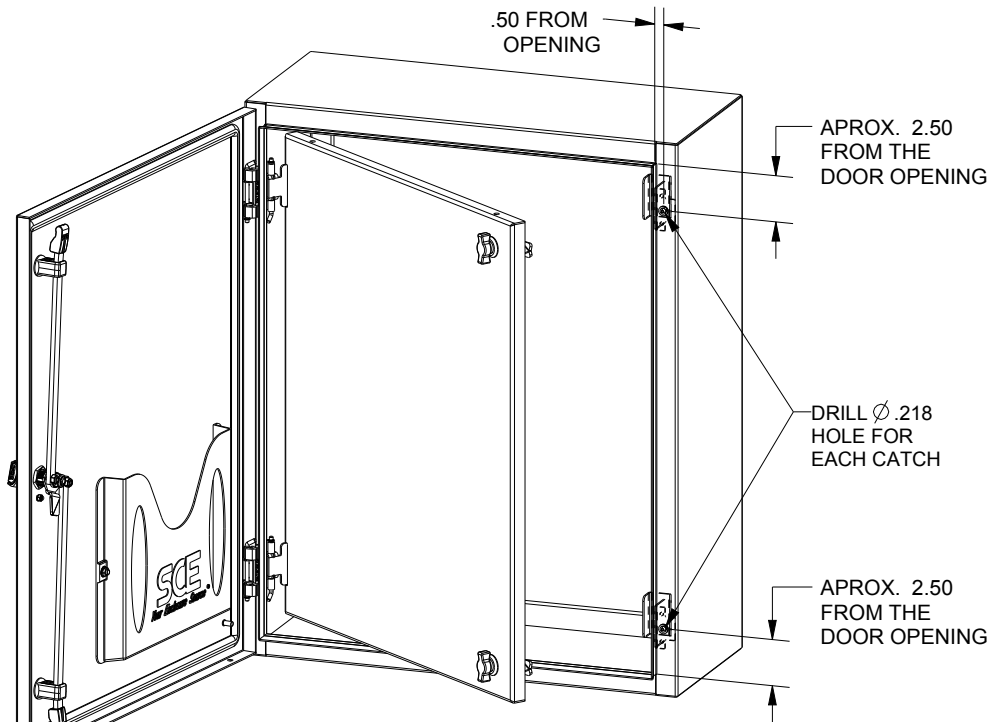

DEAD FRONT PANEL HEIGHT = ENCLOSURE OPENING - 1.50
 DEAD FRONT PANEL WIDTH = ENCLOSURE OPENING - 0.693

NOTES:

1. DEAD FRONT PANELS ARE ABLE TO SWING 120°
2. CONSTRUCTION IS 14GA. CARBON STEEL.
3. PANELS BOLT BEHIND EXISTING CONCEALED HINGES AND REQUIRE 1 ADDITIONAL HOLE DRILLED PER CATCH.

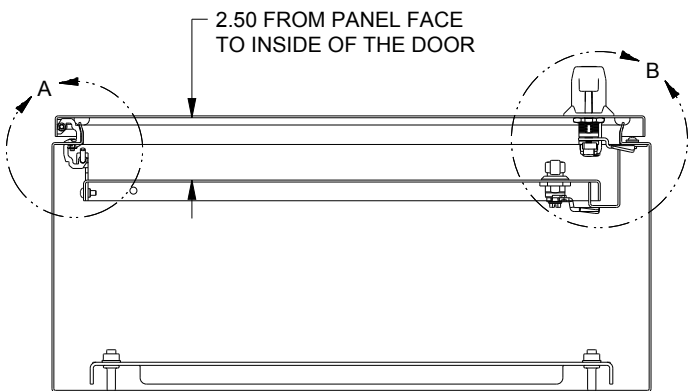
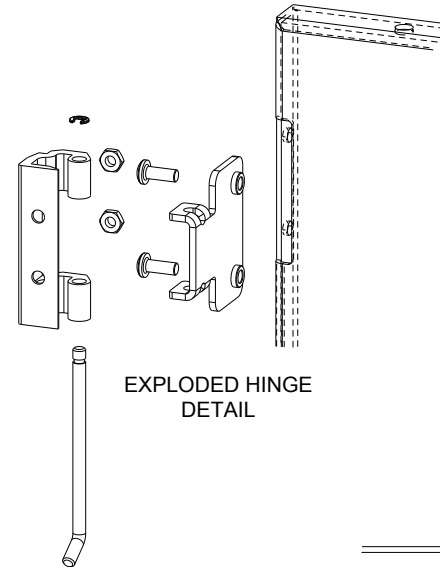

VIEW SHOWN WITH BOTTOM REMOVED

