

COUNTER BALANCE

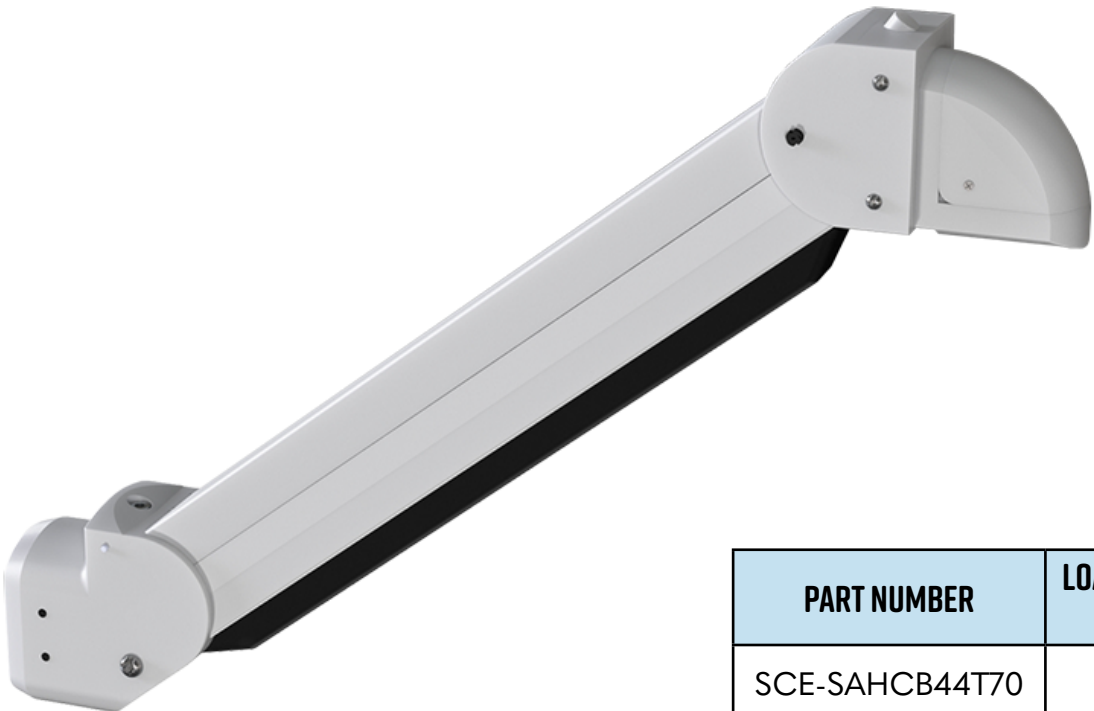

PART NUMBER	LOAD CAPACITY LBS
SCE-SAHCB44T70	44-70
SCE-SAHCB70T97	70-97
SCE-SAHCB97T132	97-132

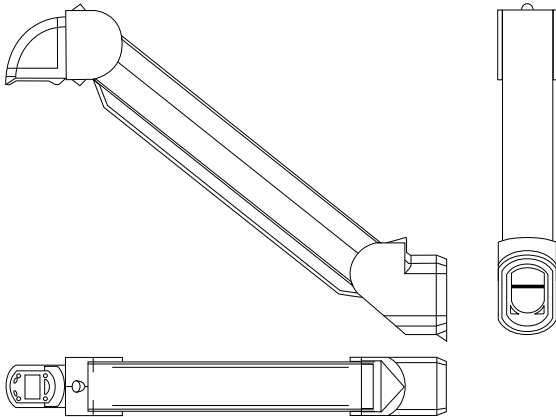
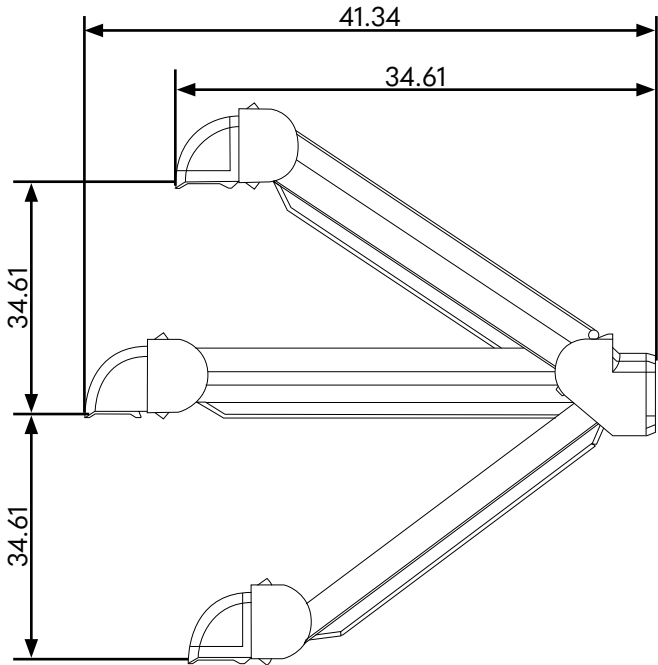

SCE-SAH310TMJ



Mounting Hole Pattern

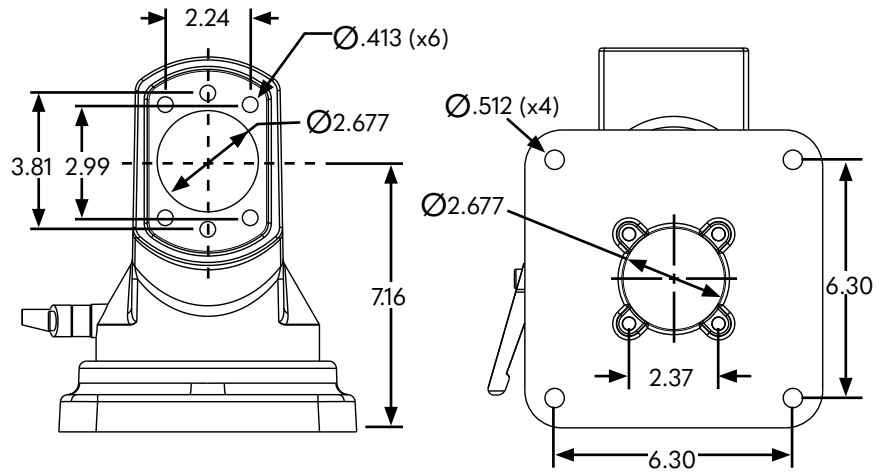

SCE-SAH230WH



Tube Opening

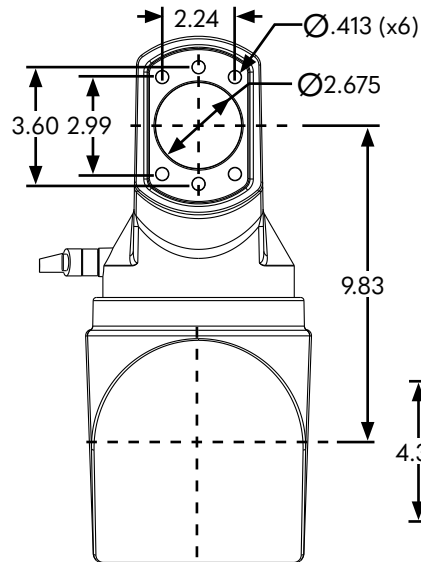

Enclosure Mounting Hole Pattern

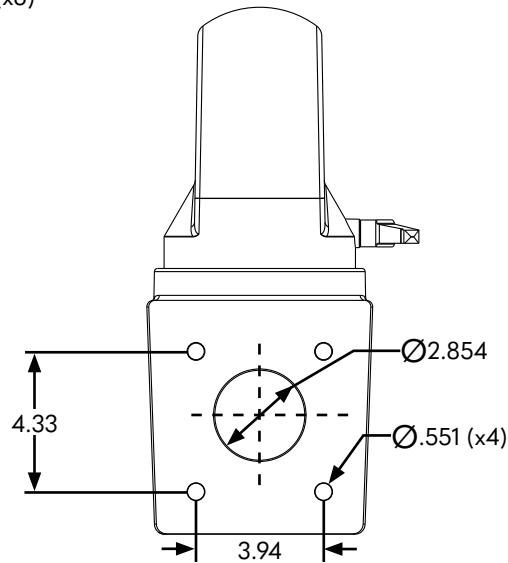

Open Profile Tube

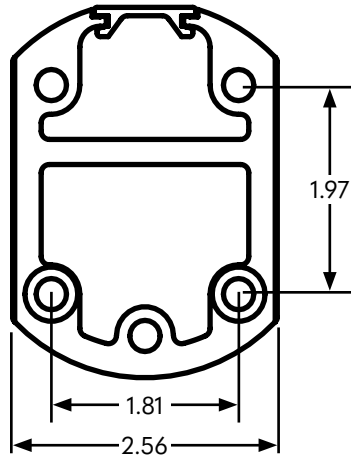
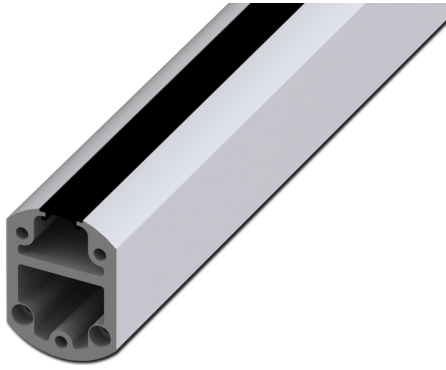

Closed Profile Tube

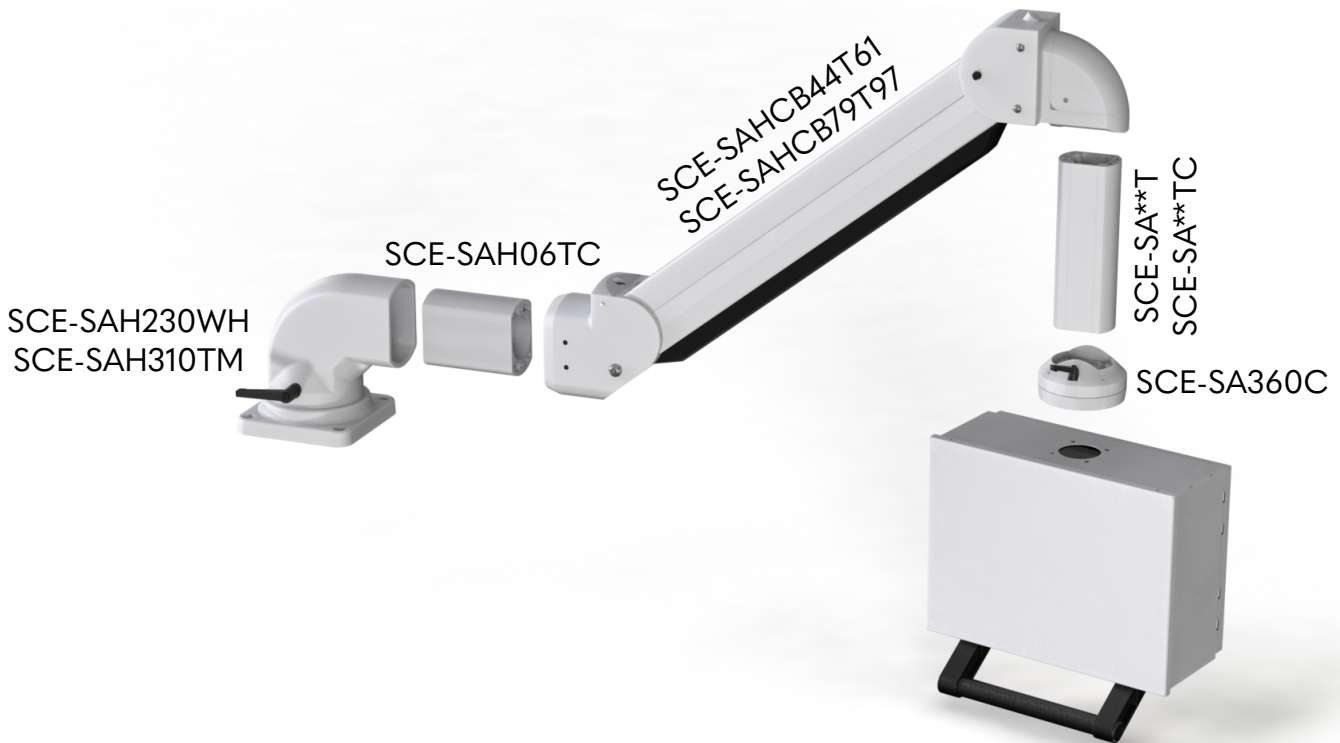
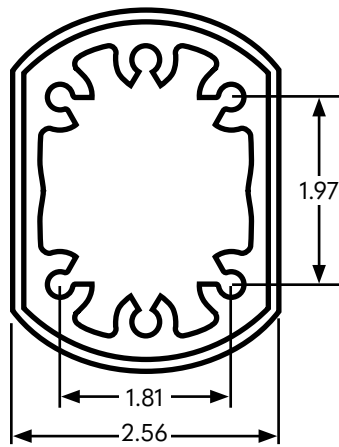

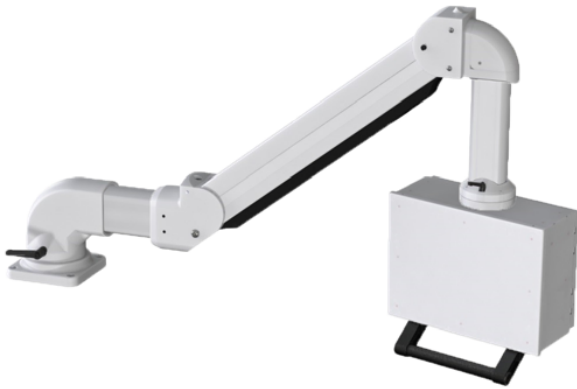

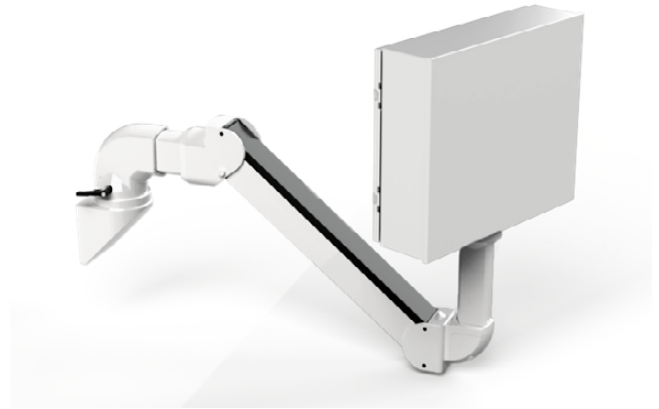

Outlet Hanging





Outlet Upright

 Before carrying out any activities (mounting control enclosure etc.), set the height adjustment position in the uppermost end position
Attention: Danger to life if disregarded!

 For all activities, use the personal safety equipment and pay attention to the system's own weight

 Do not reach

 Danger of crushed fingers

 Max. length to lower edge of control enclosure 1250 mm

 Fine adjustment of the load range

 Pay attention to the max. weight

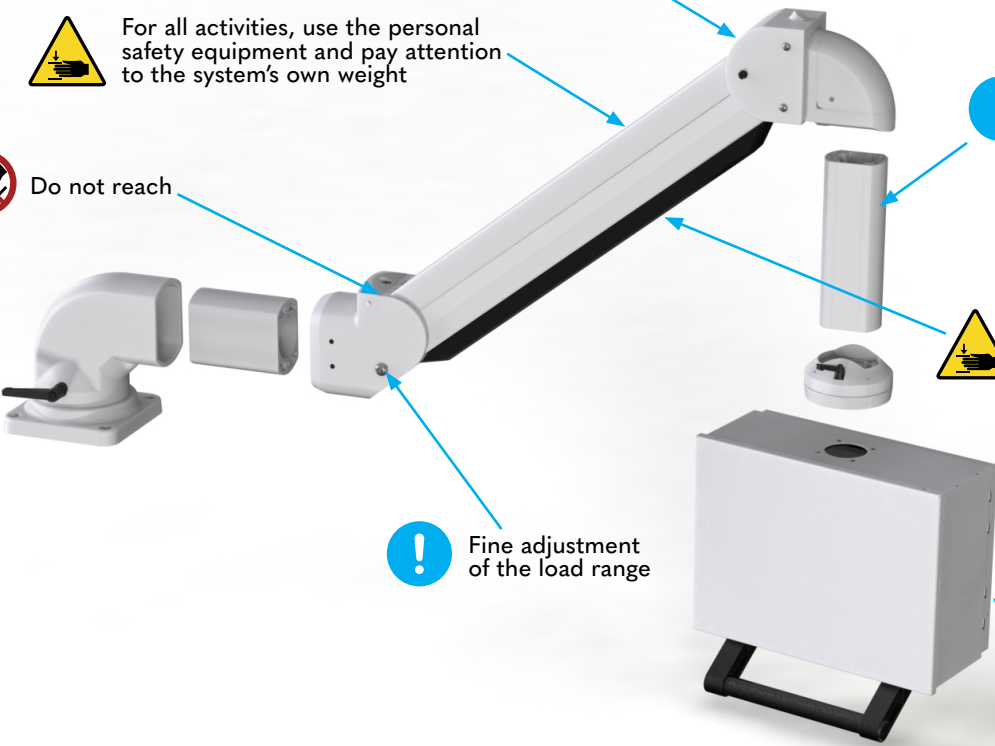

Transport and storage



- Never step underneath the load
- Do not obstruct escape routes
- Always follow the UVV (Accident Prevention Regulations) and safety regulations
- Always wear personal safety equipment

The following environmental conditions apply to storage:

- No oil-containing air
- Prevent contact with solvent-based lacquers
- Never allow the temperature to fall below the dew point

Mounting/Initial operation

Initial operation must only be carried out by personnel who have read and understood all these mounting instructions.

Generation mounting information

The mounting surface for base joints (top mounted joint and wall hinge) must be flat, angular and sufficiently able to support a load.



Before starting the mounting process, ensure that the height adjustment system is in its uppermost position and is secured with the front stop.

The system's own weight represents a risk for persons and property, so always use appropriate lifting devices and personal safety equipment.

Extensions such as control enclosures must be sufficiently fixed in position.

Details are shown in the drawings.

Normal operation:

Inspect the height adjustment system on a regular basis to ensure its correct function. If defects occur, disable function.

Steel components form part of the height adjustment system and may exhibit signs of surface corrosion in environments with a high level of humidity.

Surface corrosion does not constitute grounds for complaint.



The gas pressure springs incorporated in the counter balance arm are subject to a gradual loss of pressure. This loss can be compensated for readjusting the load setting screw.

Maintenance/servicing/cleaning:



Before starting any maintenance, servicing and cleaning operations, set the height adjustment system to its uppermost end position and secure with the front stop.

The outer surfaces of the counter balance arm must be cleaned with a clean, lint-free cloth.

Do not use cleaning agents which contain solvents.



Taking out of operation/dismantling

Before dismantling the height adjustment system, and especially before removing the control enclosure, set the height adjustment system to its uppermost position and secure with the front stop.

Disposal and return

The height adjustment system must be either a) disposed of in an environmentally-friendly way in accordance with the valid guidelines and regulations, or b) returned to the manufacturer. Saginaw Control & Engineering reserves the right to impose a charge for disposal of the counter balance arm.

Use and operating personnel

Use for the intended purpose

The height adjustment system is used for the vertical positioning of displays, monitors, control enclosures and other technical devices. The use of the height adjustment system allows these loads to be moved vertically and positioned with much less effort. Horizontal adjustment takes place in combination with the counter balance arm suspension system.

Pay careful attention to the catalogue information, the contents of these mounting instructions, and the conditions as specified in the order. The load details specified in these mounting instructions are maximum values and must not be exceeded.

Improper use

"Improper use" occurs when actions take place which conflict with use for the intended purpose.

Risks and hazards to people and material assets resulting from this suspension system can occur in the event of improper and/or incorrect use, and if the suspension system is used, assembled or handled by untrained personnel.

Improper use invalidates any liability on the part of Saginaw Control & Engineering.

Additional reasonably foreseeable misuses

If the load (control enclosure) is not mounted or approved in the uppermost position of the height adjustment system, the system moves rapidly upwards and can cause considerable personal injury and damage to property, for which Saginaw Control & Engineering does not accept any liability.

Indication load is outside the specified load ranges:

- Load too heavy: the height adjustment system collapses
- Load too light: the height adjustment system moves rapidly upwards

If the height adjustment system and the suspension system are thrown with force against the end stops, they may be destroyed

Additional reasonably foreseeable misuses:

- Use in an explosive environment (if the system is operated in potentially explosive atmospheres, spark formation can result in deflagration, fires or explosions)
- Use of the suspension system if the permitted forces and moments are exceeded
- Excessive torsion caused by the vertical profile being too long
- Inadequate machine-side mounting of the height adjustment system
- Inadequate mounting of the extensions
- Loads which exceed the system's limits
- Use in the foodstuffs industry in the event of direct contact with unpacked foodstuffs
- Outdoor use
- Use of the system in unauthorized combinations
- Use when obvious damage is present
- Use in ambient temperatures lower than the dew point
- Use in environments outside relative humidity of 0 – 85%
- Use outside the stated level of ingress protection
- Use in an extremely soiled environment
- Use in an extremely dusty atmosphere
- Use in a solvent-contaminated atmosphere
- Movement of living organisms/creatures
- Use in liquids

Who is permitted to use, mount and operate the system?

Only those personnel who have read and understood all these operating instructions are permitted to use, mount and operate the height adjustment system.

Safety

Safety information

Saginaw Control & Engineering has manufactured this height adjustment system in accordance with the current state of technology and the existing safety regulations. However, persons and property can still be at risk from this system if it is used incorrectly or not in accordance with the intended purpose or if the safety information is not followed. Expert operation and careful maintenance ensure the high performance and availability of the system.

Faults or circumstances which may affect safety must be remedied immediately.

Every person who is involved in the mounting, use, operation or maintenance of the counter balance arm and suspension system must have read and understood the mounting instructions.

These include that

- You understand the safety information in the text.
- You acquaint yourself with the arrangement and function of the various modes of operation and use.

The use, mounting and operation of this height adjustment system must only be carried out by personnel who are envisaged for this purpose. All work carried out on and with the counter balance arm must only take place in accordance with these instructions.

Always pay attention to the general, national and operational safety instructions.

Before any work takes place, the user must ensure that no persons or objects are occupying the area of risk.

Special safety information

- All work relating to the height adjustment system must only be carried out in accordance with the existing instructions
- Always wear personal safety equipment during work
- For safety reasons, unauthorized modifications or alterations to the height adjustment are not permitted

Safety signs



General prohibition signs



Do not reach inside



General warning sign



Warning against hand injuries



General mandatory signs

Mounting

1. Slide the counter balance arm onto the heavy duty tube profile
2. Tighten all four grub screw (M12x20; 365 Nm)

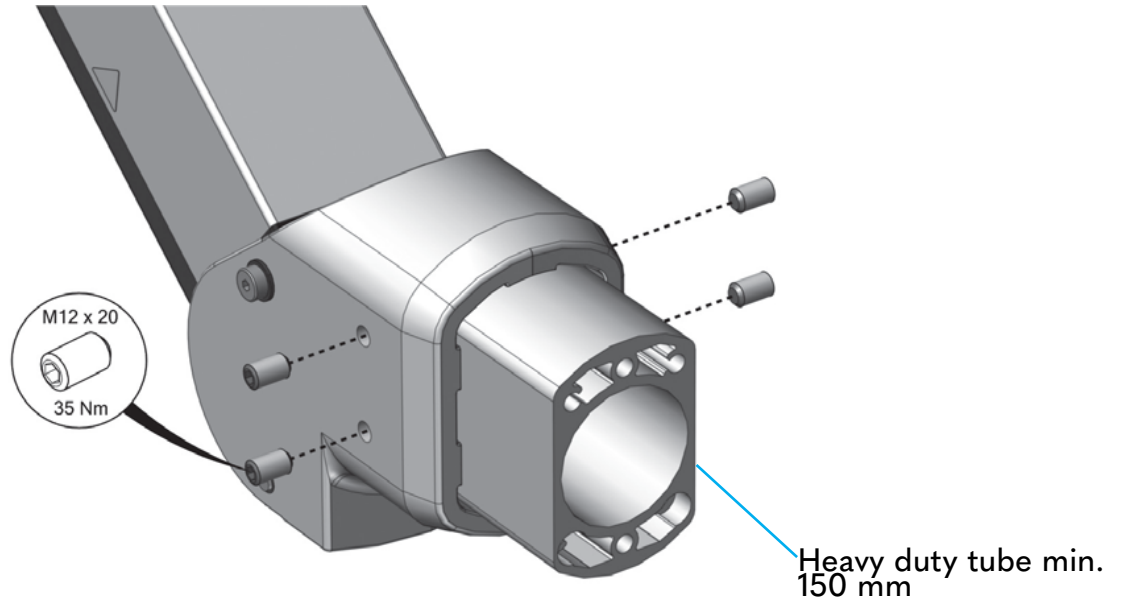

3. Remove the cover cap to fix the vertical counter balance arm profile (M8x50; 30 Nm)
4. Remove the cover plate

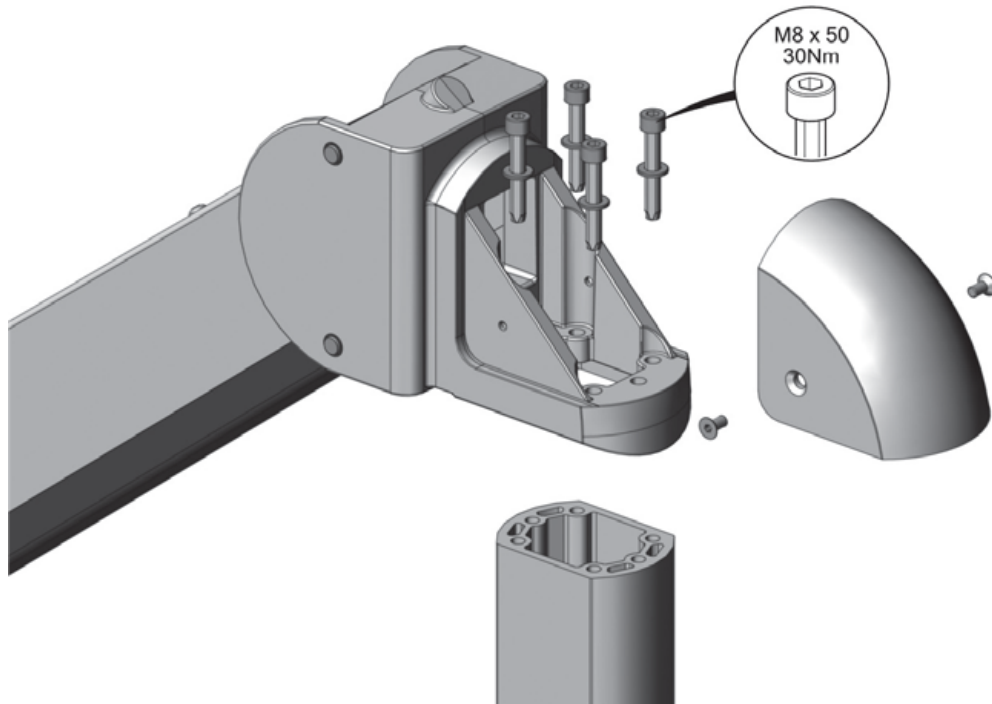

5. Install all attachments

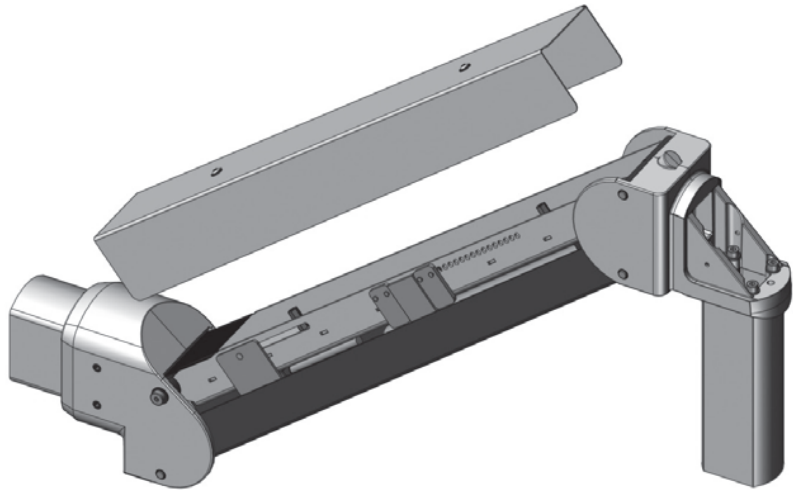

6. Remove the front stop

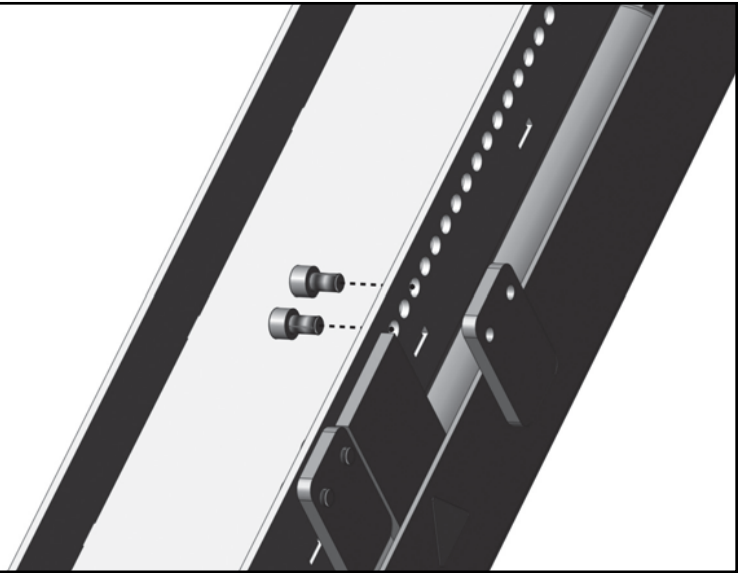

7. Adjust the fine adjustment of the counter balance arm to the exact weight of the attachments

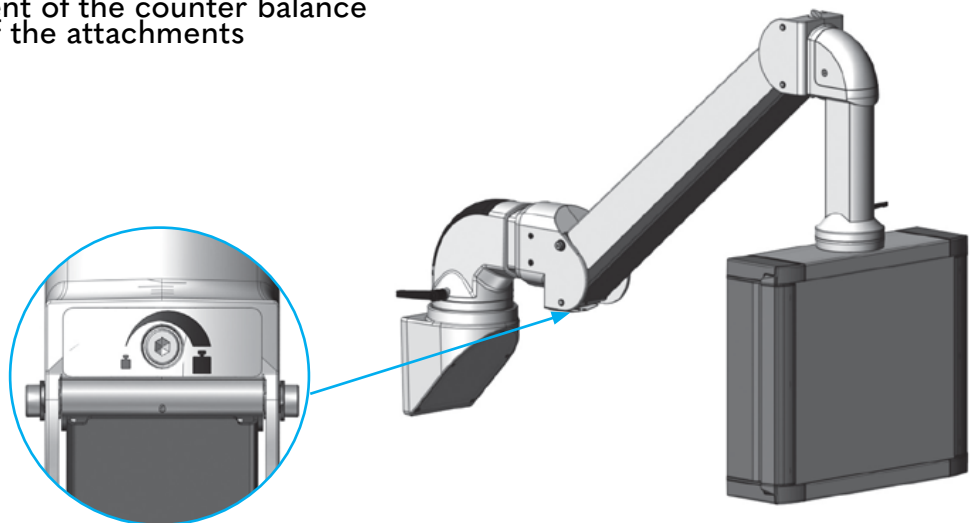

8. The system is set at the factory so that it holds every position as soon as the fine adjustment has been made. If you want increased stiffness, you can tighten the adjusting nut a little more.

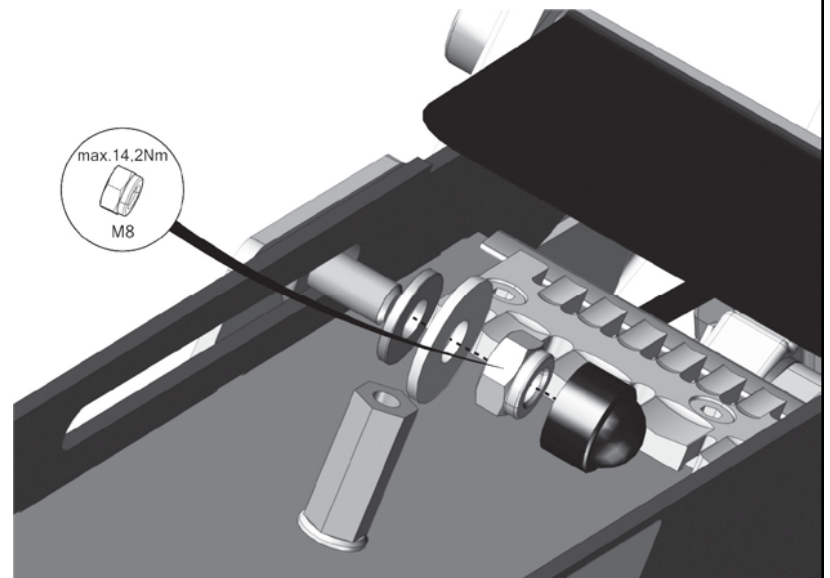

8. Bring the system into a horizontal position and adjust the stops according to your requirements. Stop 1 limits the stroke upwards, stop 2 downward. There is a limitation of approx. 5° per hole in the grid.

Always use both end stops!

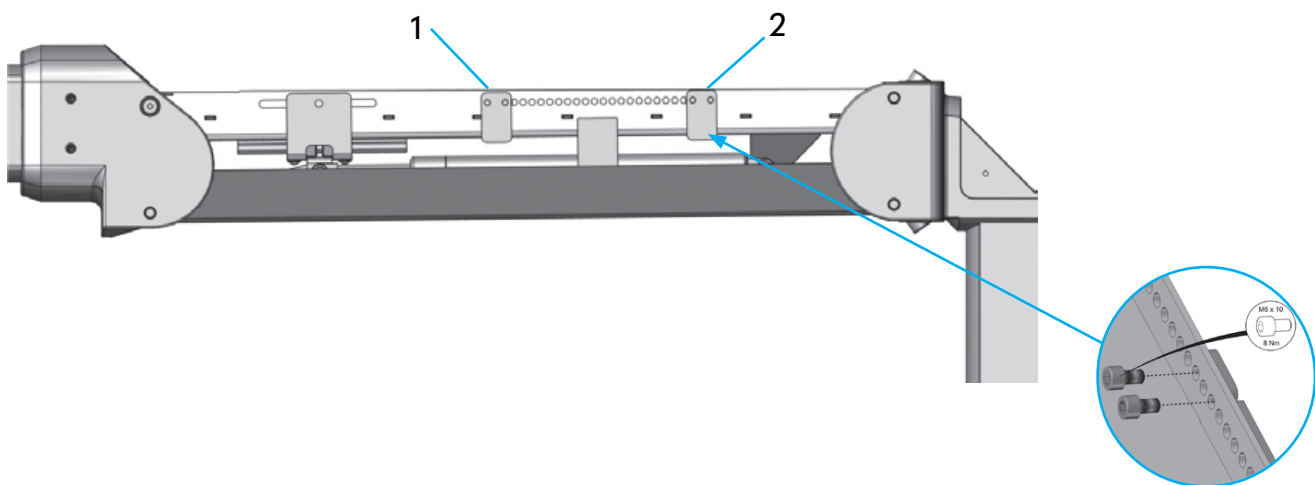

10. Route the cables through the counter balance arm in the top position
11. Secure the cables for strain relief using the strain relief and cable ties on the carrier

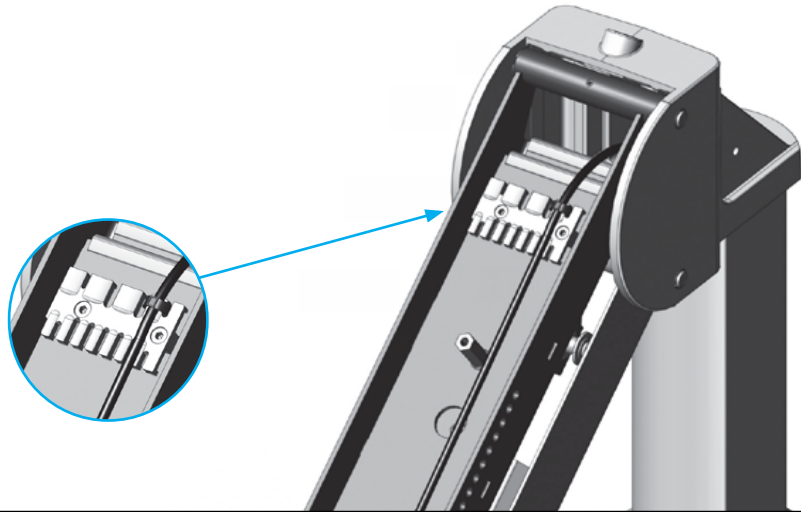

12. Screw the cover cap and cover plate back onto the counter balance arm

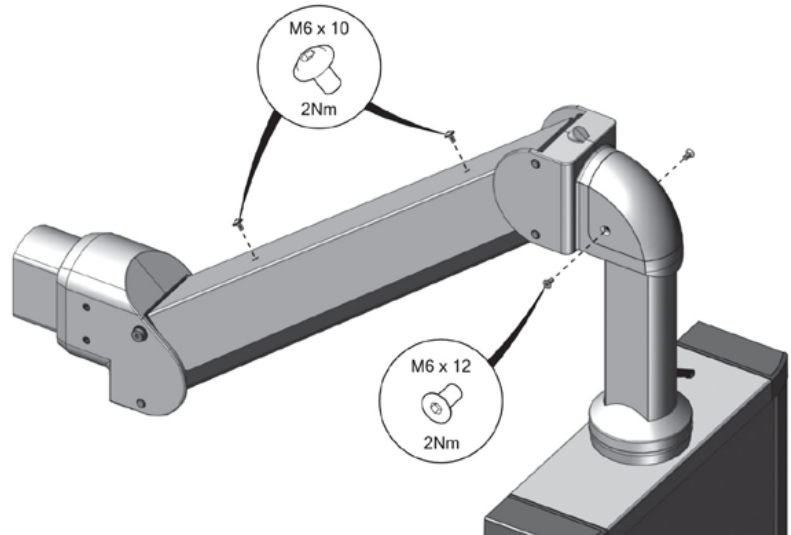

ATTENTION: Gas pressure springs are used in the system. These lose pressure over time. To compensate for this, it may be necessary to readjust the fine adjustment. This can easily be done from the outside in the assembled system. If the maximum setting range is reached and the system continues to sag, the gas springs must be replaced.

