

SAGINAW CONTROL & ENGINEERING HALF SWING-OUT PANEL INSTALLATION (FOR FREE-STANDING ENCLOSURE) Sheet 1 of 2

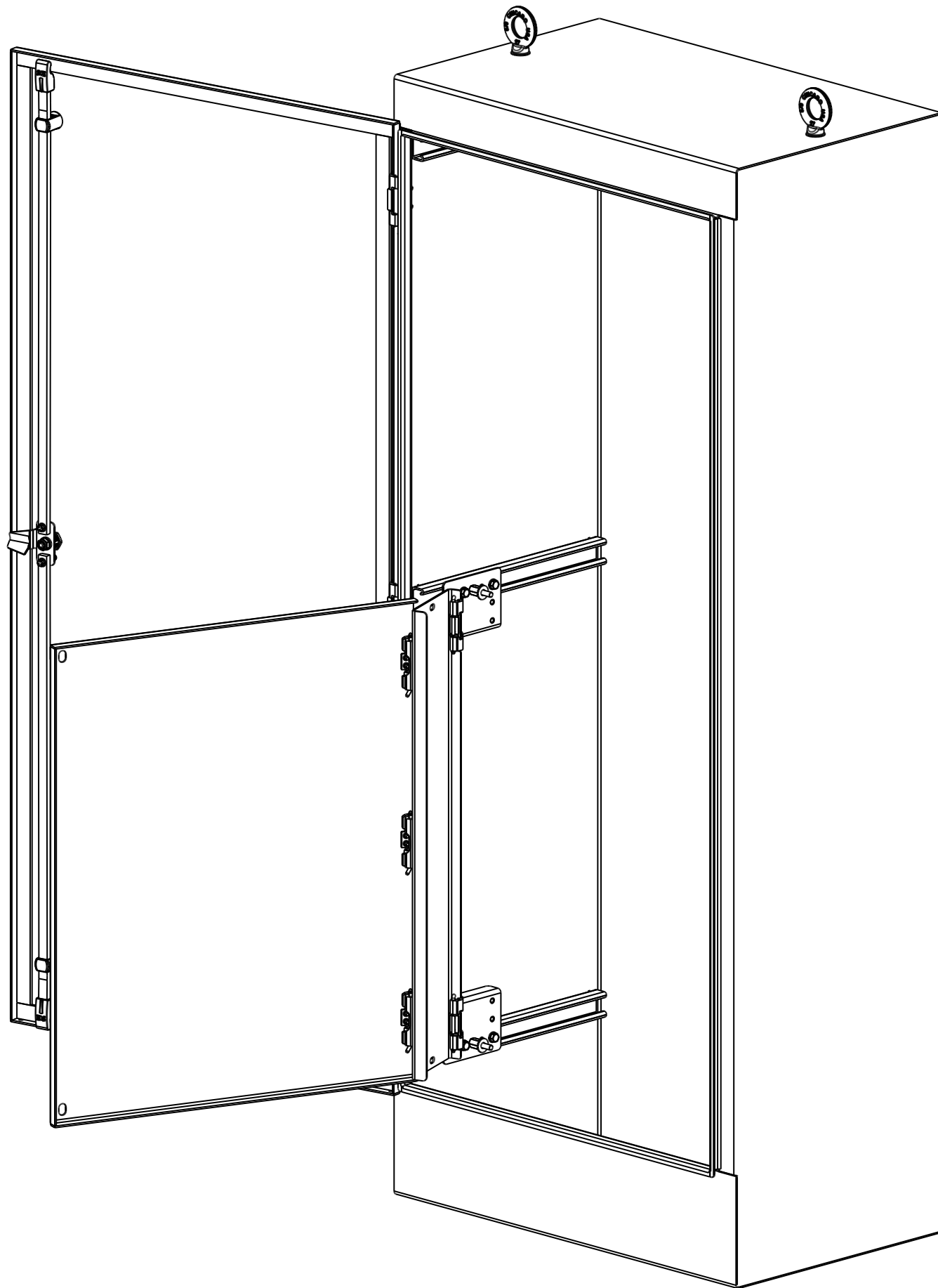

FRONT ISOMETRIC VIEW FOR REFERENCE
SHOWING HALF SWING-OUT PANEL INSTALLED

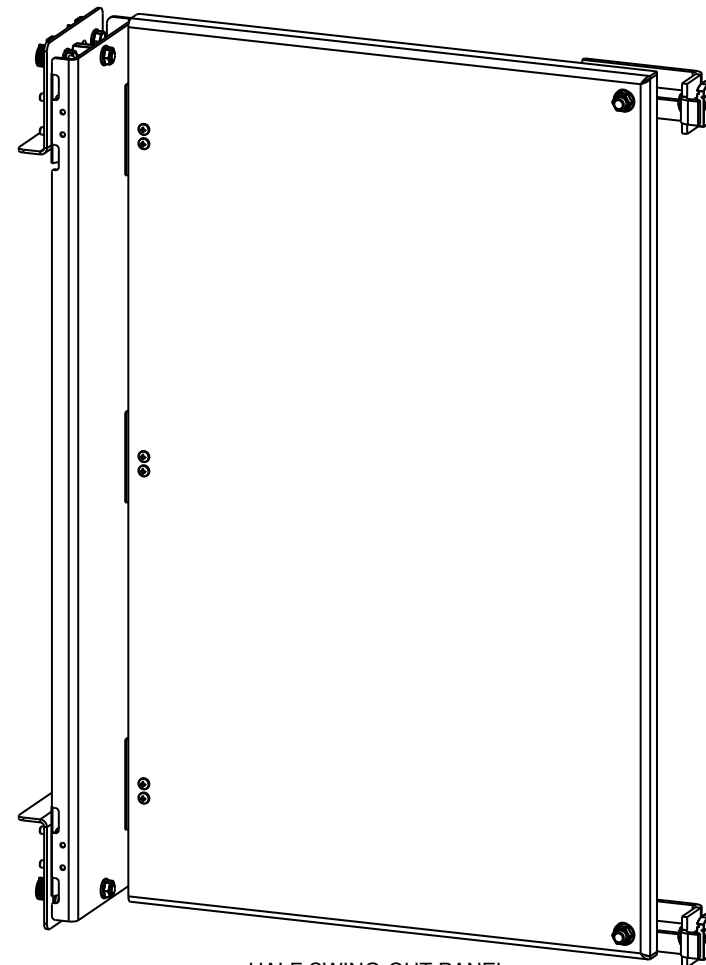

HALF SWING-OUT PANEL
FRONT ISOMETRIC VIEW

HALF SWING-OUT PANEL BILL OF MATERIAL			
ITEM	QTY	PART DESCRIPTION	PART I.D.
1	2	Nut, Serrated Flange, 3/8-16 Steel, Zinc Clear Plated	100904
2	2	Channel Nut, 3/8-16, 0.81 to 1.00 x 1.63in, Steel, Zinc	100920
3	2	Nut, Serrated Flange, 5/16-18 Steel, Zinc Clear Plated	100921
4	2	Nut, Coupling, 5/16-18 X 0.875, Steel, Zinc Clear	101015
5	5	Hinge, Large Concealed, Zinc Die Cast, Clear	101369
6	2	Support, Free-Standing Panel, 5.00 X 1.75, Steel, Zinc Clear	101432
7	2	Nut, Coupling, 3/8-16 X 1.13 X 0.75, Steel, Zinc Clear	101663
8	5	Retainer, E-Clip, 0.03"Thick X 0.16" ID X 0.35" OD, Stainless	101670
9	2	Bolt, Carriage, 3/8-16 X 2.00, Steel, Zinc Clear	102406
10	6	Screw, Pan Head Phillips, 10-32 X 1/2", Steel, Zinc Clear	102470
11	2	Bolt, Hex Head, Serrated Flange, 3/8-16 x 3/4, Steel, Zinc	102493
12	4	Screw, Hex Head, Serrated Flange, 5/16-18 x 3/4, Steel, Zinc	102496
13	10	Screw, Button Head, Socket, 1/4-20 X 5/8, Stainless	102532
14	4	Channel Nut, 5/16-18, 1.38 to 1.63 x 1.63in, Steel, Zinc	108141
15	2	Washer, Flat, 0.31, Steel, Zinc Clear	109205
16	2	Screw, Hex Head, Full Thread, 5/16-18 X 1.50", Steel, Zinc Clear	112052
17	3	Dead Front Hinge Bracket, Steel, Zinc Clear	114875
18	1	Hinge Bracket, Swing-Out Panel	NA
19	5	Hinge Pin, Large Concealed, Stainless, Included with 101369	NA
20	2	Mounting Bracket, Swing-Out Panel	NA
21	1	Panel, Swing-Out Panel	NA

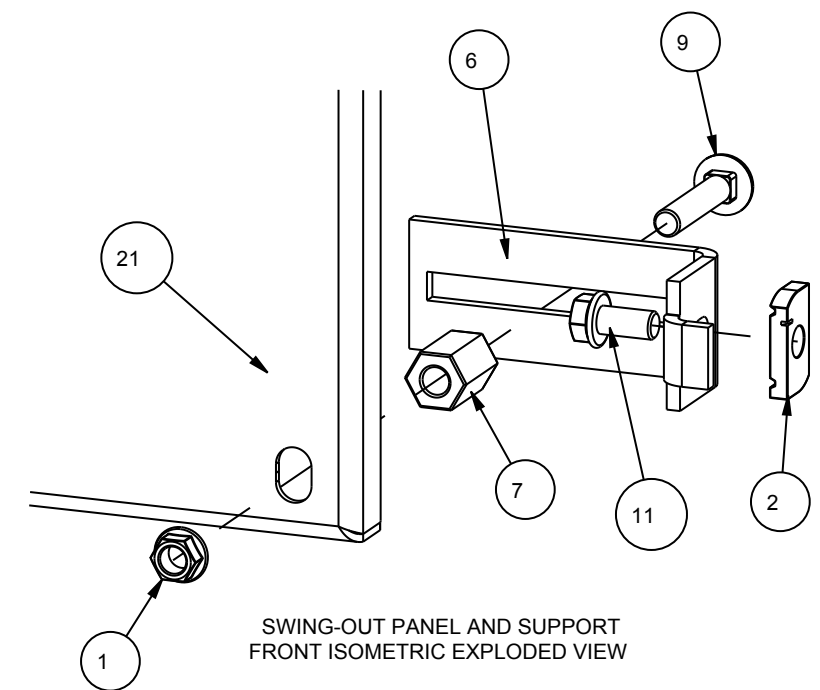

SWING-OUT PANEL AND SUPPORT
FRONT ISOMETRIC EXPLODED VIEW

SAGINAW CONTROL & ENGINEERING HALF SWING-OUT PANEL INSTALLATION (FOR FREE-STANDING ENCLOSURE) Sheet 2 of 2

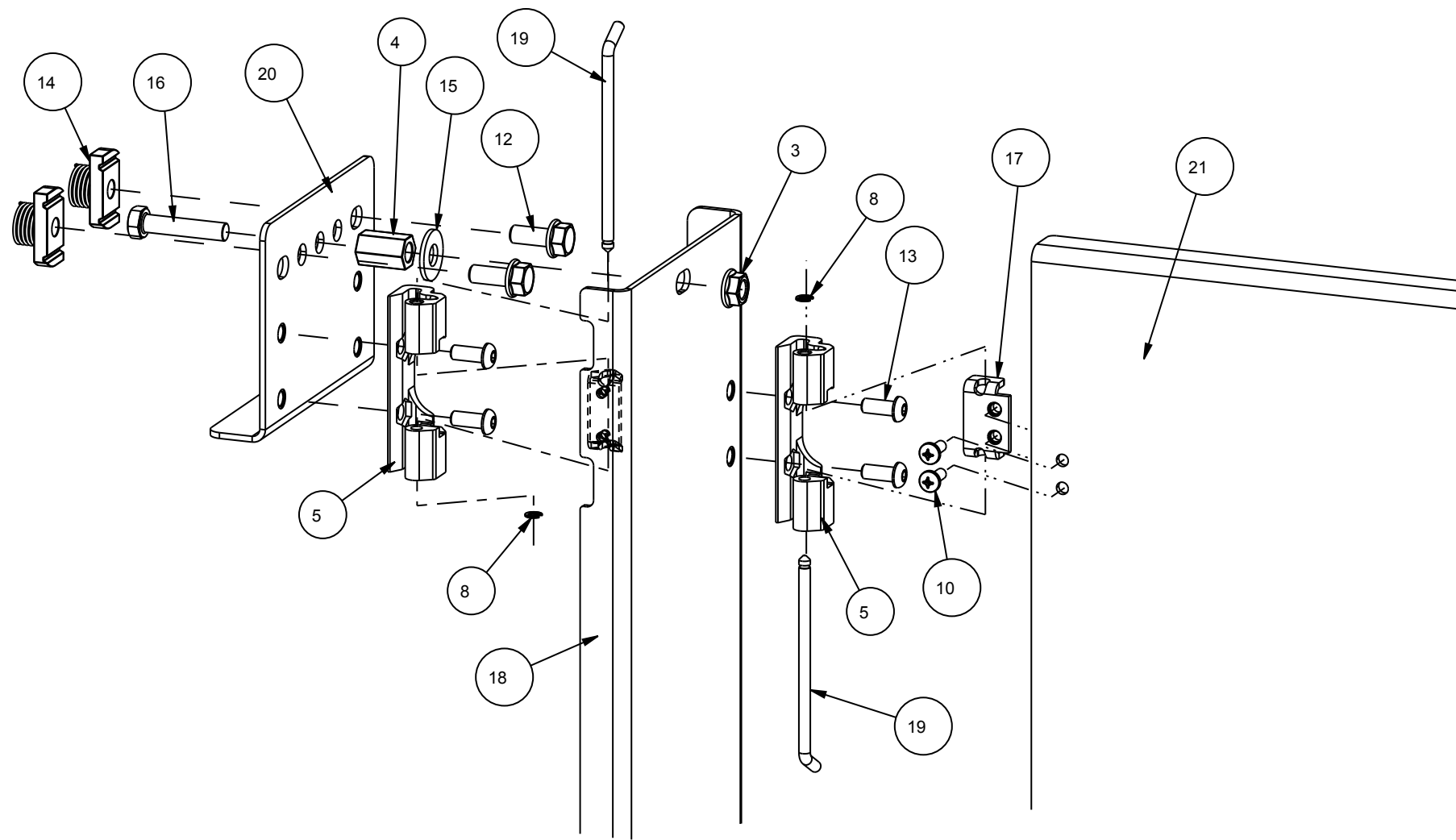

MOUNTING BRACKET & HINGE BRACKET
FRONT ISOMETRIC EXPLODED VIEW

HALF SWING-OUT PANEL BILL OF MATERIAL			
ITEM	QTY	PART DESCRIPTION	PART I.D.
1	2	Nut, Serrated Flange, 3/8-16 Steel, Zinc Clear Plated	100904
2	2	Channel Nut, 3/8-16, 0.81 to 1.00 x 1.63in, Steel, Zinc	100920
3	2	Nut, Serrated Flange, 5/16-18 Steel, Zinc Clear Plated	100921
4	2	Nut, Coupling, 5/16-18 X 0.875, Steel, Zinc Clear	101015
5	5	Hinge, Large Concealed, Zinc Die Cast, Clear	101369
6	2	Support, Free-Standing Panel, 5.00 X 1.75, Steel, Zinc Clear	101432
7	2	Nut, Coupling, 3/8-16 X 1.13 X 0.75, Steel, Zinc Clear	101663
8	5	Retainer, E-Clip, 0.03"Thick X 0.16" ID X 0.35" OD, Stainless	101670
9	2	Bolt, Carriage, 3/8-16 X 2.00, Steel, Zinc Clear	102406
10	6	Screw, Pan Head Phillips, 10-32 X 1/2", Steel, Zinc Clear	102470
11	2	Bolt, Hex Head, Serrated Flange, 3/8-16 x 3/4, Steel, Zinc	102493
12	4	Screw, Hex Head, Serrated Flange, 5/16-18 x 3/4, Steel, Zinc	102496
13	10	Screw, Button Head, Socket, 1/4-20 X 5/8, Stainless	102532
14	4	Channel Nut, 5/16-18, 1.38 to 1.63 x 1.63in, Steel, Zinc	108141
15	2	Washer, Flat, 0.31, Steel, Zinc Clear	109205
16	2	Screw, Hex Head, Full Thread, 5/16-18 x 1.50", Steel, Zinc Clear	112052
17	3	Dead Front Hinge Bracket, Steel, Zinc Clear	114875
18	1	Hinge Bracket, Swing-Out Panel	NA
19	5	Hinge Pin, Large Concealed, Stainless, Included with 101369	NA
20	2	Mounting Bracket, Swing-Out Panel	NA
21	1	Panel, Swing-Out Panel	NA

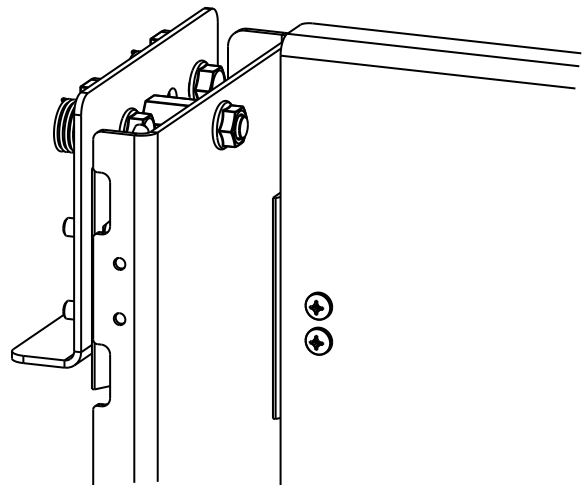

MOUNTING BRACKET & HINGE BRACKET
FRONT ISOMETRIC NON-EXPLODED VIEW

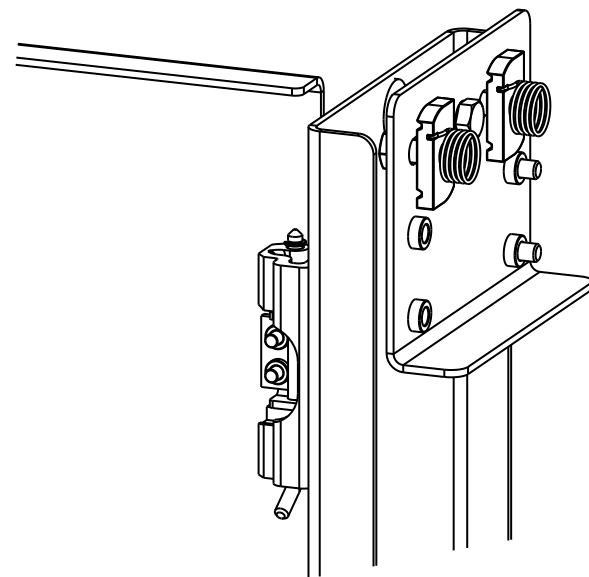

MOUNTING BRACKET & HINGE BRACKET
REAR ISOMETRIC NON-EXPLODED VIEW

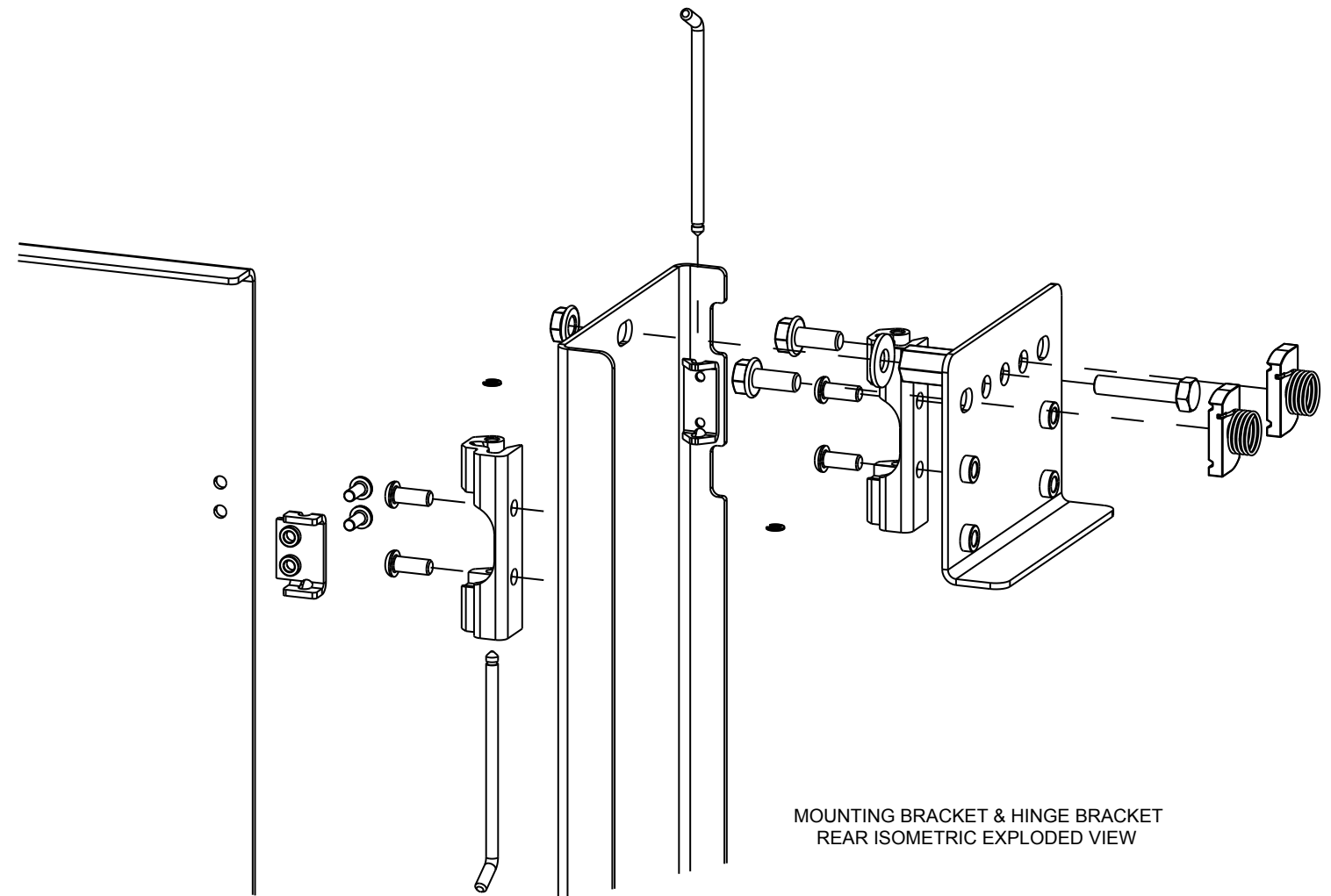

MOUNTING BRACKET & HINGE BRACKET
REAR ISOMETRIC EXPLODED VIEW