

SAGINAW CONTROL & ENGINEERING SPEC-DF-IMS-INSTMAN SPECIFICATIONS, IMS, DEAD FRONT

NOTES:

1. DEAD FRONT PANELS SWING 115°.
2. CONSTRUCTION IS 14GA H.R.S.
3. PANELS BOLT IN BEHIND EXISTING CONCEALED HINGES.

W = DOOR OPENING WIDTH - 0.75 [18.93]

H = ENCLOSURE HEIGHT - 4.91 [124.65]

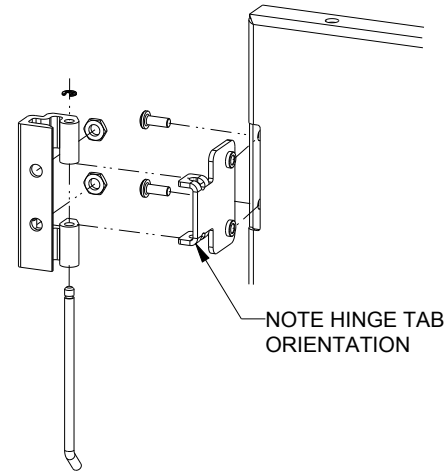
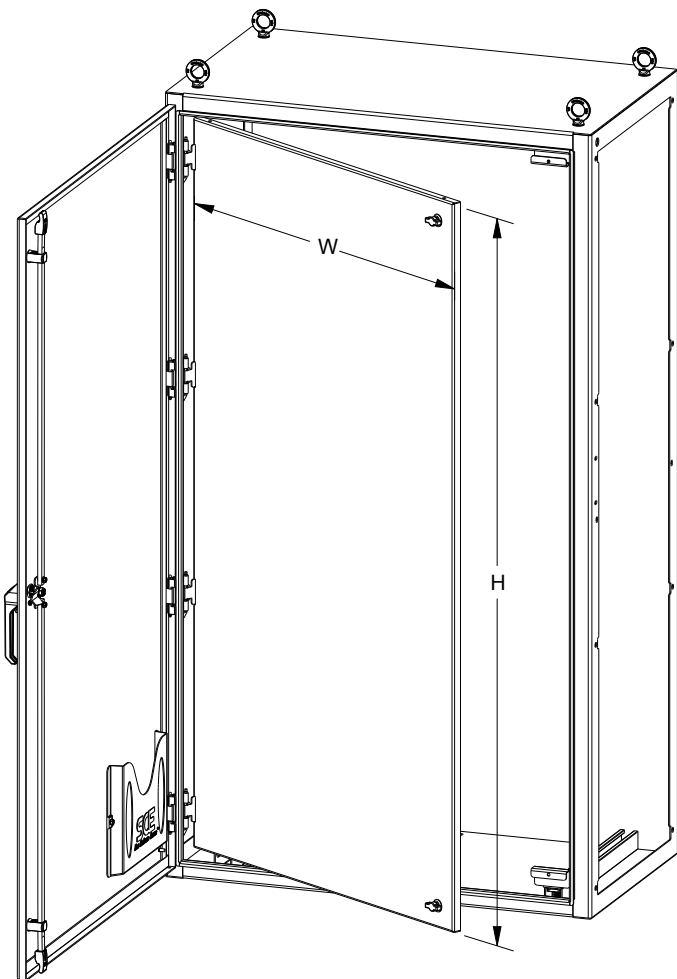

EXPLODED HINGE DETAIL

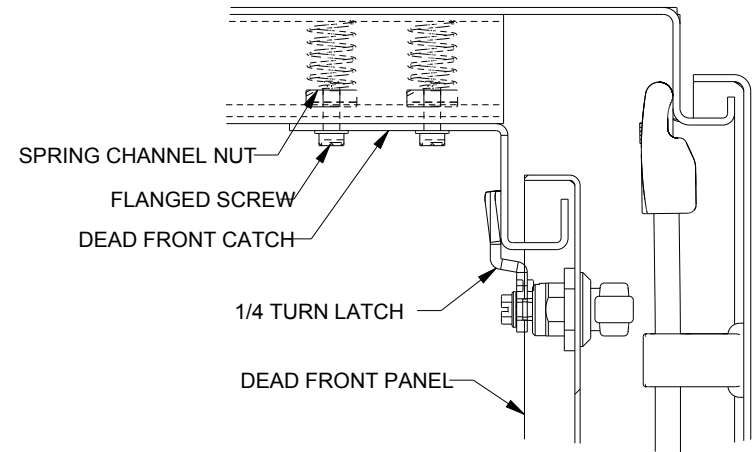

INTERIOR RIGHT SIDE SECTION VIEW

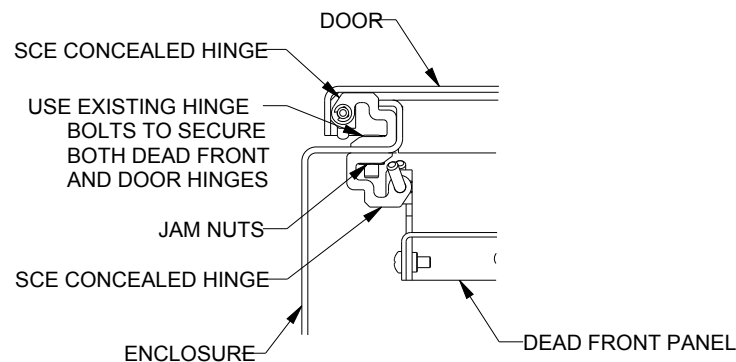
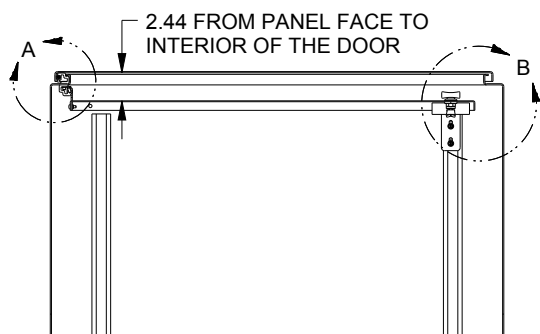

DETAIL A

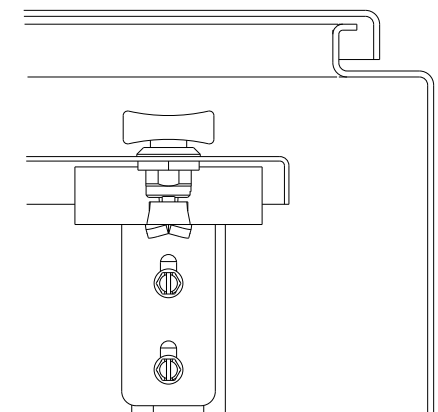

DETAIL B