

# SCE-PLKJIC INSTALLATION

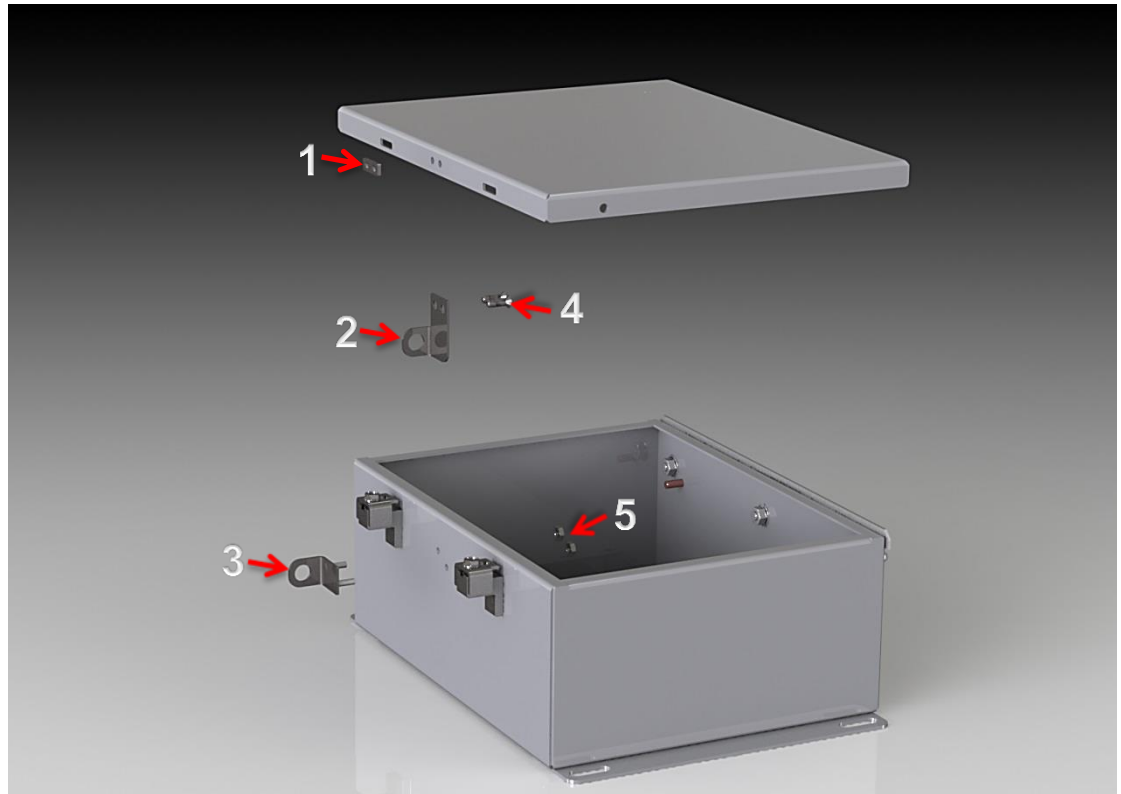

1. Nut Plate
2. Door Staple
3. Body Staple
4. 6-32 Flat Head Screw (x2)
5. 6-32 Zinc Plated Keps Nut (x2)

- A. Pre-drill two 5/32 diameter holes in the door. Shown in "Enclosure Door Drill Detail"
- B. Pre-drill two 5/32 diameter holes in body. Shown in "Enclosure Body Drill Detail"
- C. Align and place nut plate (Item 1) on exterior and door staple (Item 2) on interior of the door with the pre-drilled holes from step A.
- D. Fasten together the door staple and nut plate with Two 6-32 flat head screws (Item 4) onto the door.
- E. Place the body staple (Item 3) into the pre-drilled holes in the enclosure from step B.
- F. Fasten the body staple to the body with two 6-32 keps nut (Item 5) on the interior of the body.

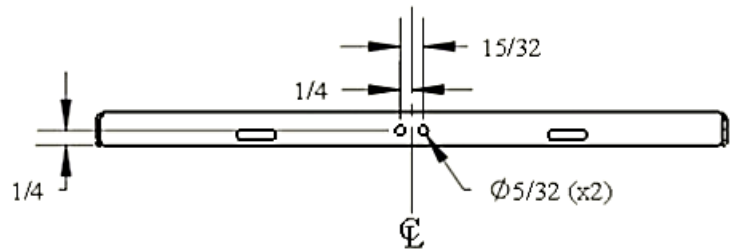

ENCLOSURE DOOR DRILL DETAIL

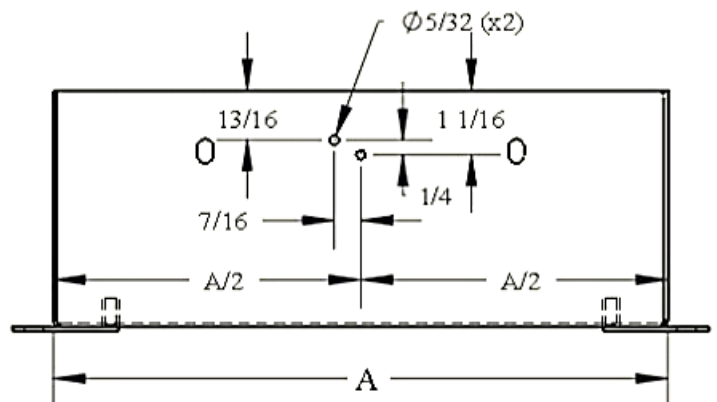

ENCLOSURE BODY DRILL DETAIL