

# SAGINAW CONTROL & ENGINEERING DEAD FRONT, TWO DOOR WITH CENTER CHANNEL

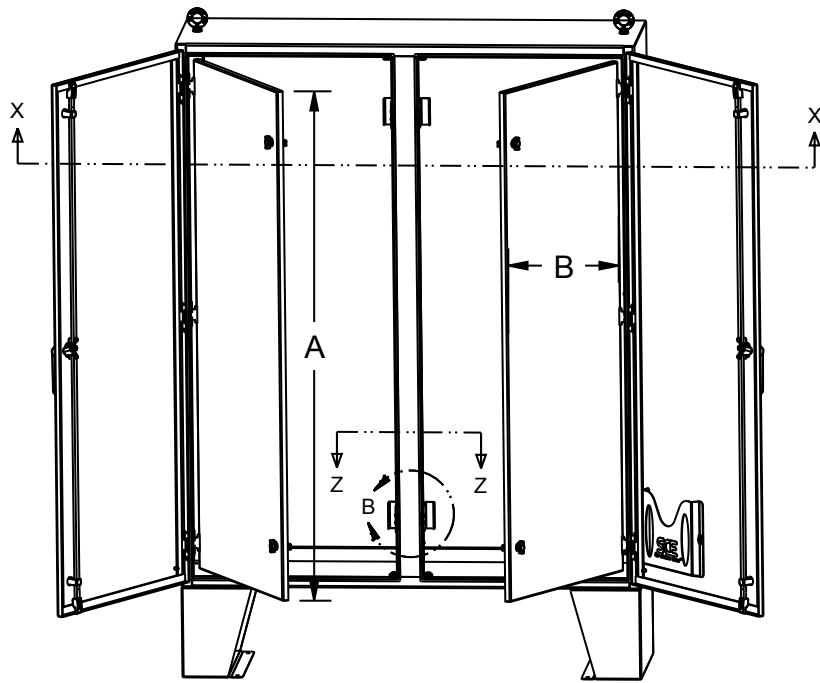

DEAD FRONT PANEL SIZE:  
A = ENCL. OPENING - 1.50"  
B = ENCL. OPENING - 0.75"

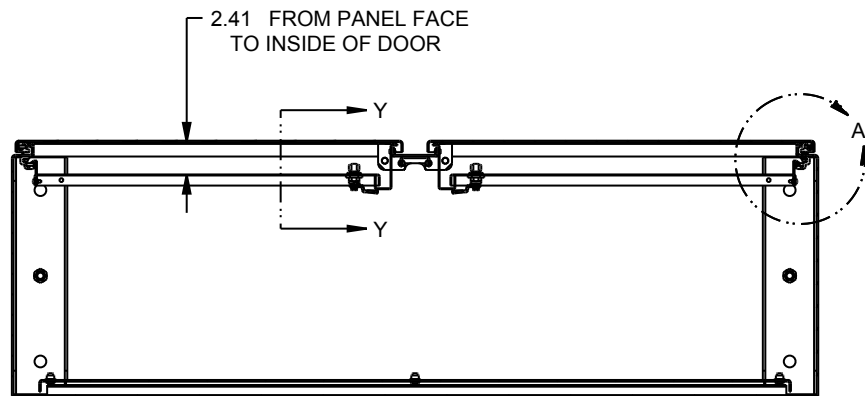
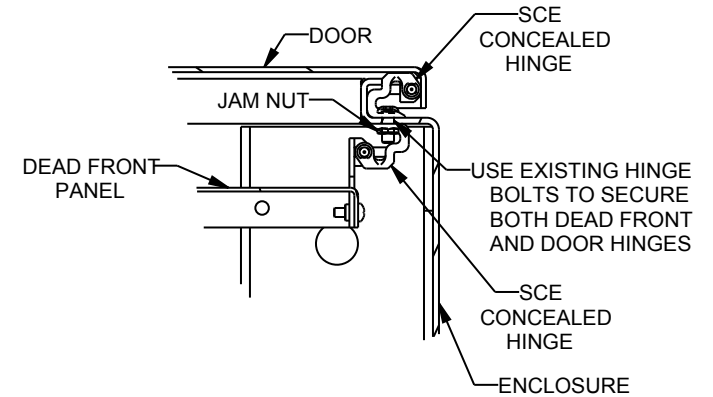
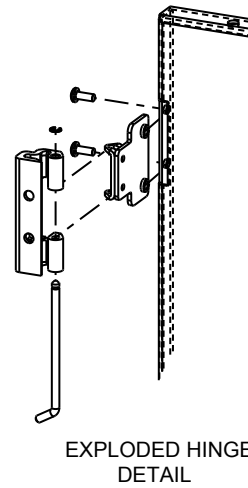

VIEW SHOWN WITH THE  
DOORS & DEAD FRONT CLOSED  
BOTTOM VIEW SECTION X-X

