

DRILL PATTERN FOR A-B DOOR ROD

1/4 X 1/2 DOOR ROD.

2 RODS
2 OR 3 POINT
LATCHING

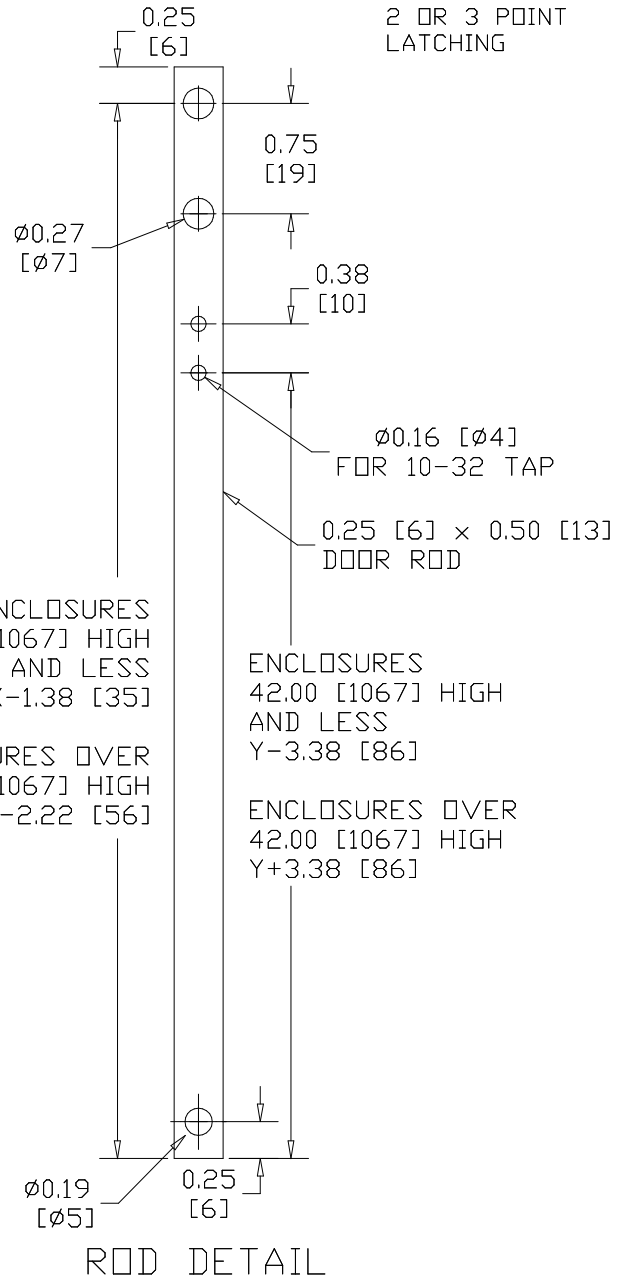
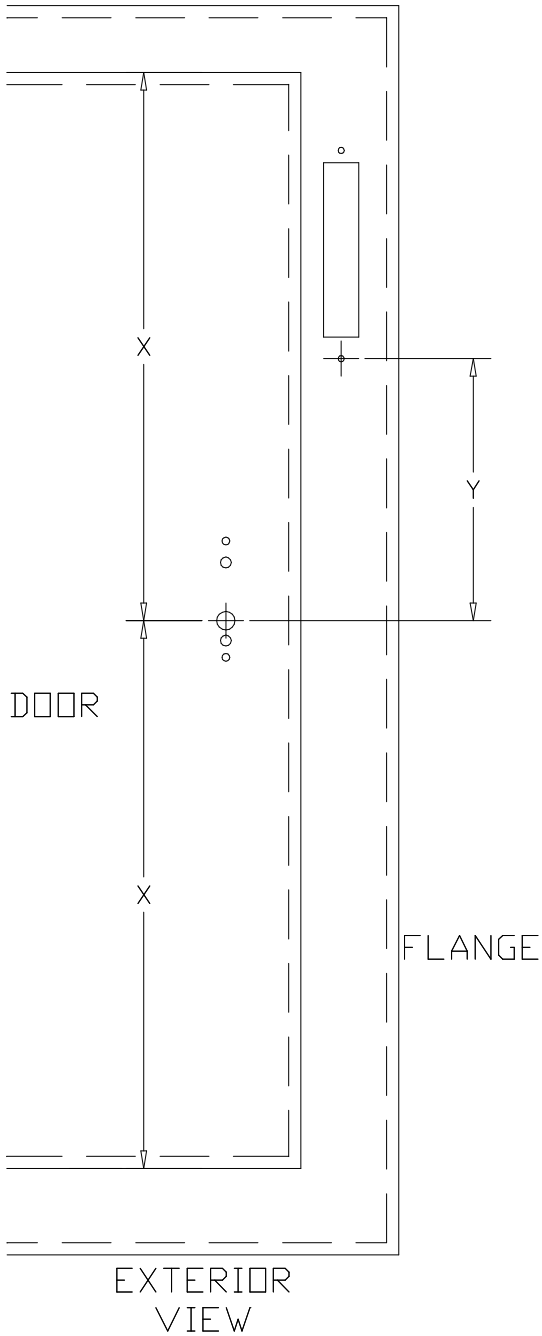

ENCLOSURES 42.00 [1067] HIGH AND LESS
USE AB 1494F-L1 OR 1494F-L2

ENCLOSURES OVER 42.00 [1067] HIGH USE
AB 1494F-L3, 1494F-L4, OR 1494V-L3