

# SWING-OUT RACK ASSEMBLY

SCE-7230SOF19  
 SCE-7236SOF19  
 SCE-9036SOF19

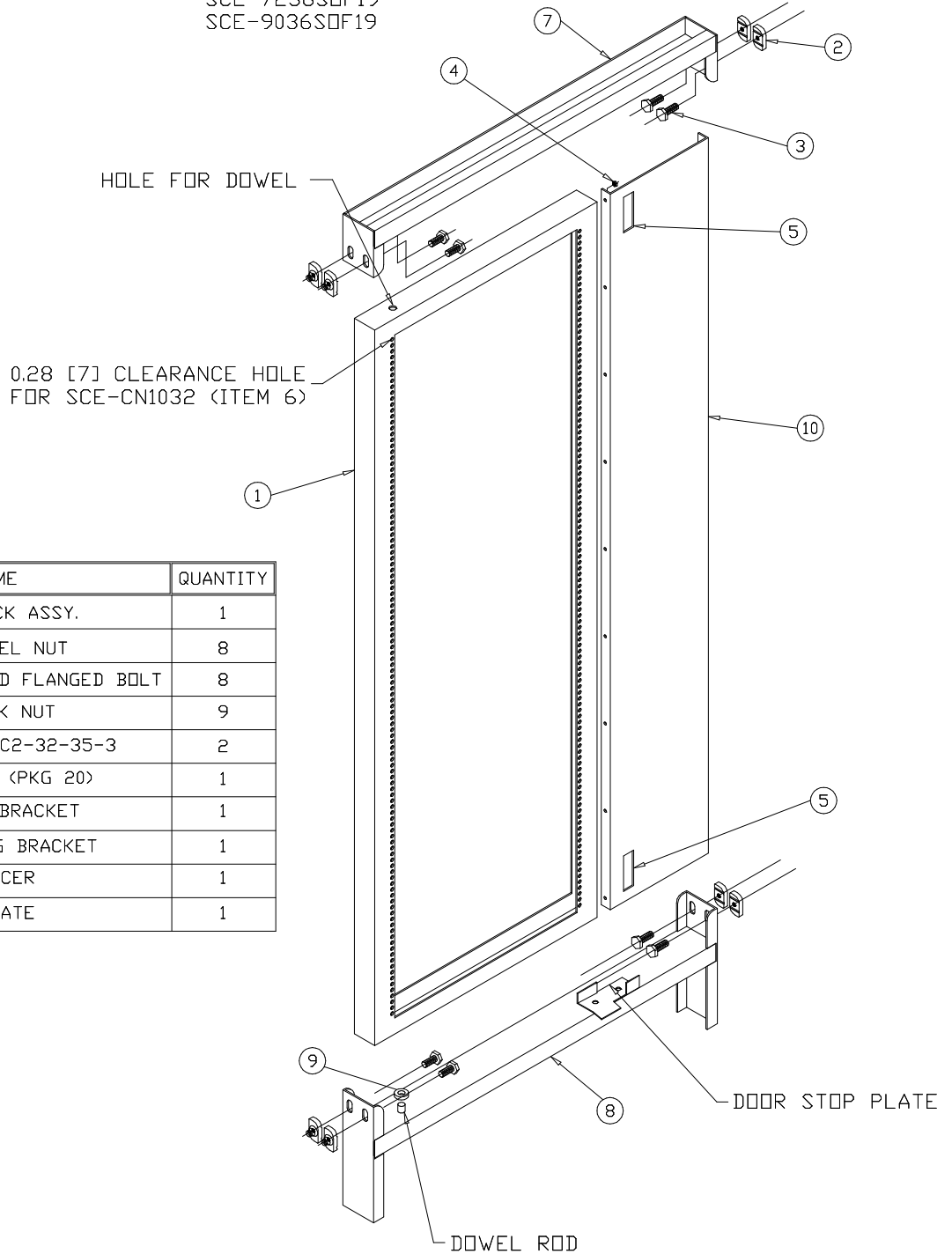

ITEM #	PART NAME	QUANTITY
1	SWING-OUT RACK ASSY.	1
2	3/8-16 CHANNEL NUT	8
3	3/8-16 X 3/4 SERRATED FLANGED BOLT	8
4	10-32 K-LOCK NUT	9
5	LATCH, (SOUTHCD) C2-32-35-3	2
6	10-32 CLIP NUT, (PKG 20)	1
7	TOP MOUNTING BRACKET	1
8	BOTTOM MOUNTING BRACKET	1
9	NYLON SPACER	1
10	SPACER PLATE	1

## INSTALLATION INSTRUCTIONS

STEP 1: ATTACH THE TOP MOUNTING BRACKET (ITEM 7) TO SIDE CHANNELS AT THE TOP OF THE ENCLOSURE USING ITEM #S 2 AND 3.

STEP 2: ATTACH THE BOTTOM MOUNTING BRACKET (ITEM 8) TO SIDE CHANNELS AT THE BOTTOM OF THE ENCLOSURE USING ITEM #S 2 AND 3.

STEP 3: ASSEMBLE SPACER PLATE (ITEM 10) TO SWING OUT RACK (ITEM 1) USING ITEM # 4.

STEP 4: INSERT NYLON SPACER (ITEM 9) ONTO THE BOTTOM MOUNTING BRACKET DOWEL ROD.

STEP 5: LIFT THE ASSEMBLED RACK AND SPACER PLATE ONTO THE DOWEL ROD ON THE TOP MOUNTING BRACKET WHILE LINING UP THE BOTTOM HOLE WITH THE BOTTOM MOUNTING BRACKET DOWEL ROD. (TOP AND BOTTOM MOUNTING BRACKETS ARE DESIGNED WITH OBOUNDED SLOTS FOR ADJUSTING THE HEIGHT.)