

SWING PANEL SCE-ELSP3

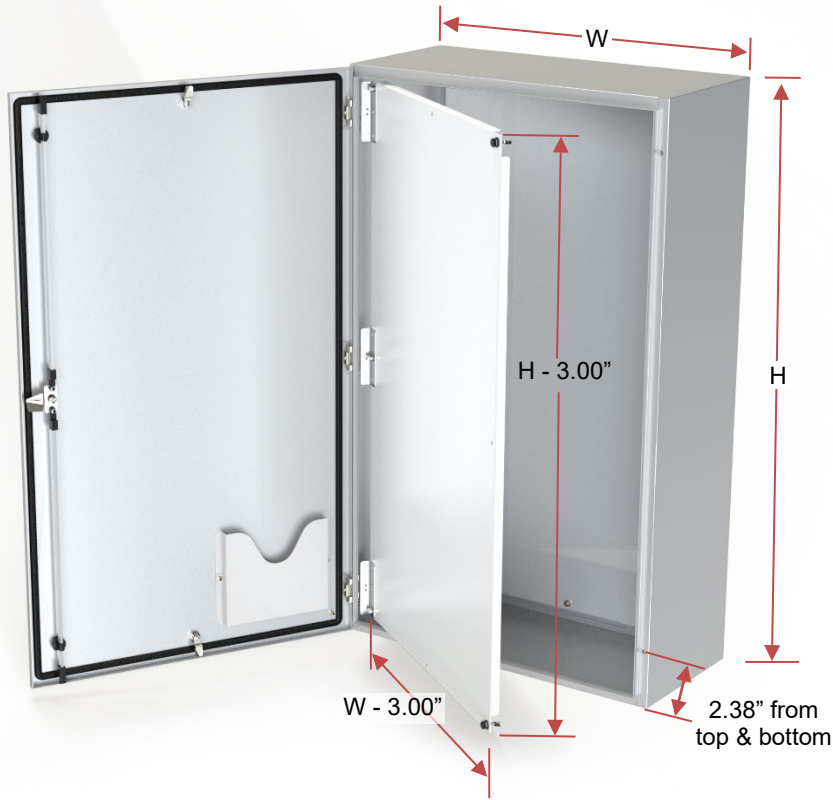

1. SCE-ELSP3 is intended for concealed hinge enclosures that are > 16.00" in height. For enclosures <=16.00" use SCE-ELSP.
2. Panel swing is approximately 115°.
3. Panel construction is 11GA H.R.S.
4. Panel kit concealed hinges bolt in behind existing concealed hinges on enclosures and required 2 additional holes to be drilled in the flange on the latching side for catches.
5. Panel kits are compatible with flat or bent subpanels. Panel is NOT included with kit.

