

# ELJ HINGED WINDOW ENCLOSURE

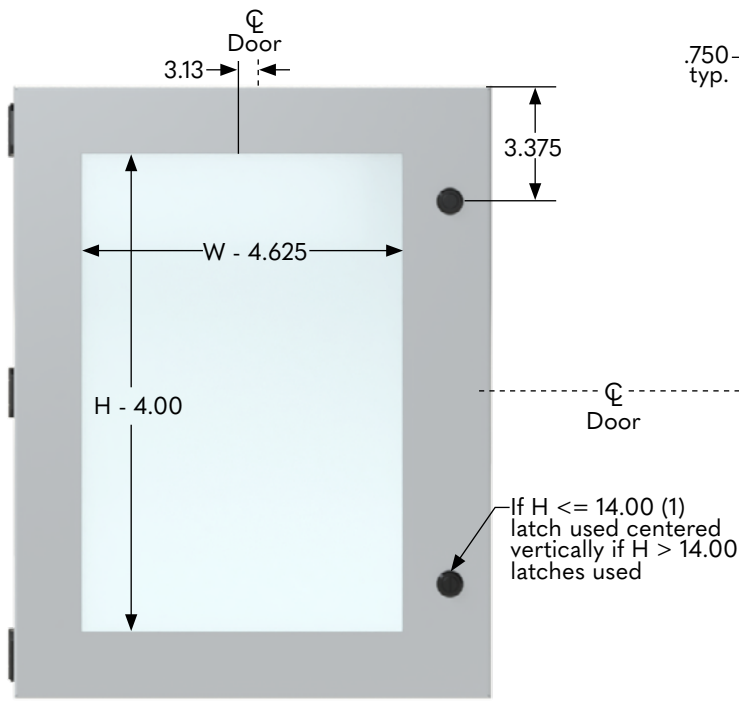

Front View

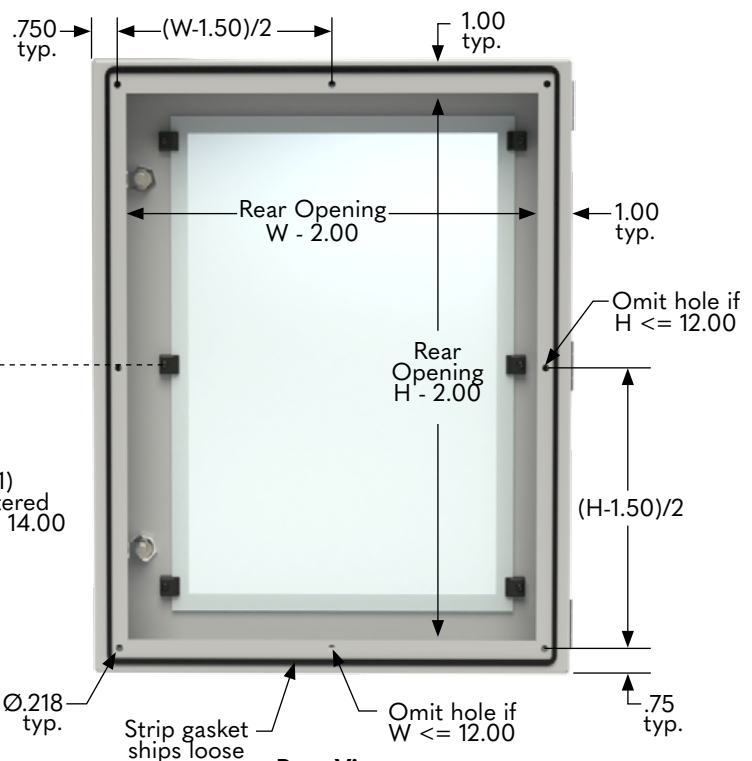

Rear View

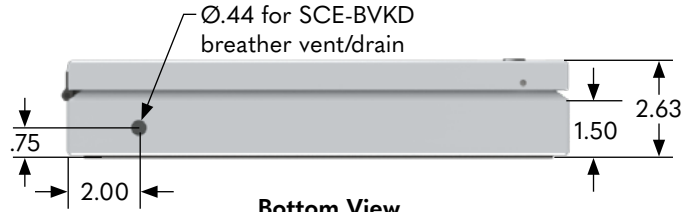

Bottom View

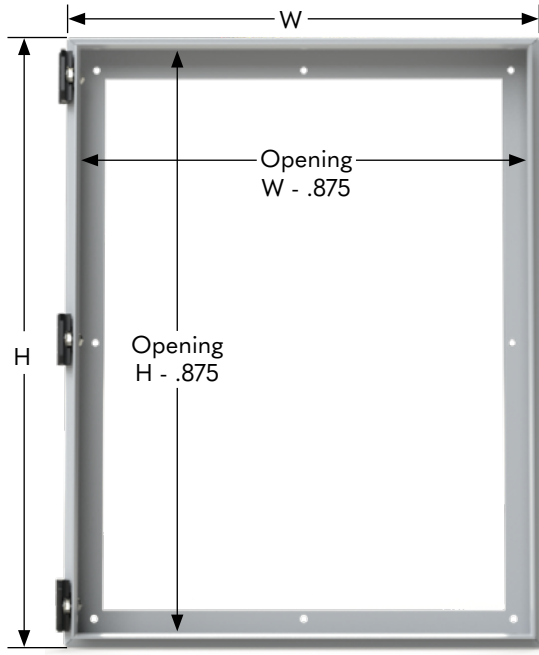

Front View (Door removed)

Catalog Number	Height	Width
SCE-HWK1014	10	14
SCE-HWK1014SS	10	14
SCE-HWK1212	12	12
SCE-HWK1212LG	12	12
SCE-HWK1212SS	12	12
SCE-HWK1216	12	16
SCE-HWK1216SS	12	16
SCE-HWK1312	13	12
SCE-HWK1418	14	18
SCE-HWK1418SS	14	18
SCE-HWK1620	16	20
SCE-HWK1620SS	16	20
SCE-HWK1814	18	14
SCE-HWK1814LG	18	14
SCE-HWK1814SS	18	14
SCE-HWK2218	22	18
SCE-HWK2218LG	22	18
SCE-HWK2218SS	22	18

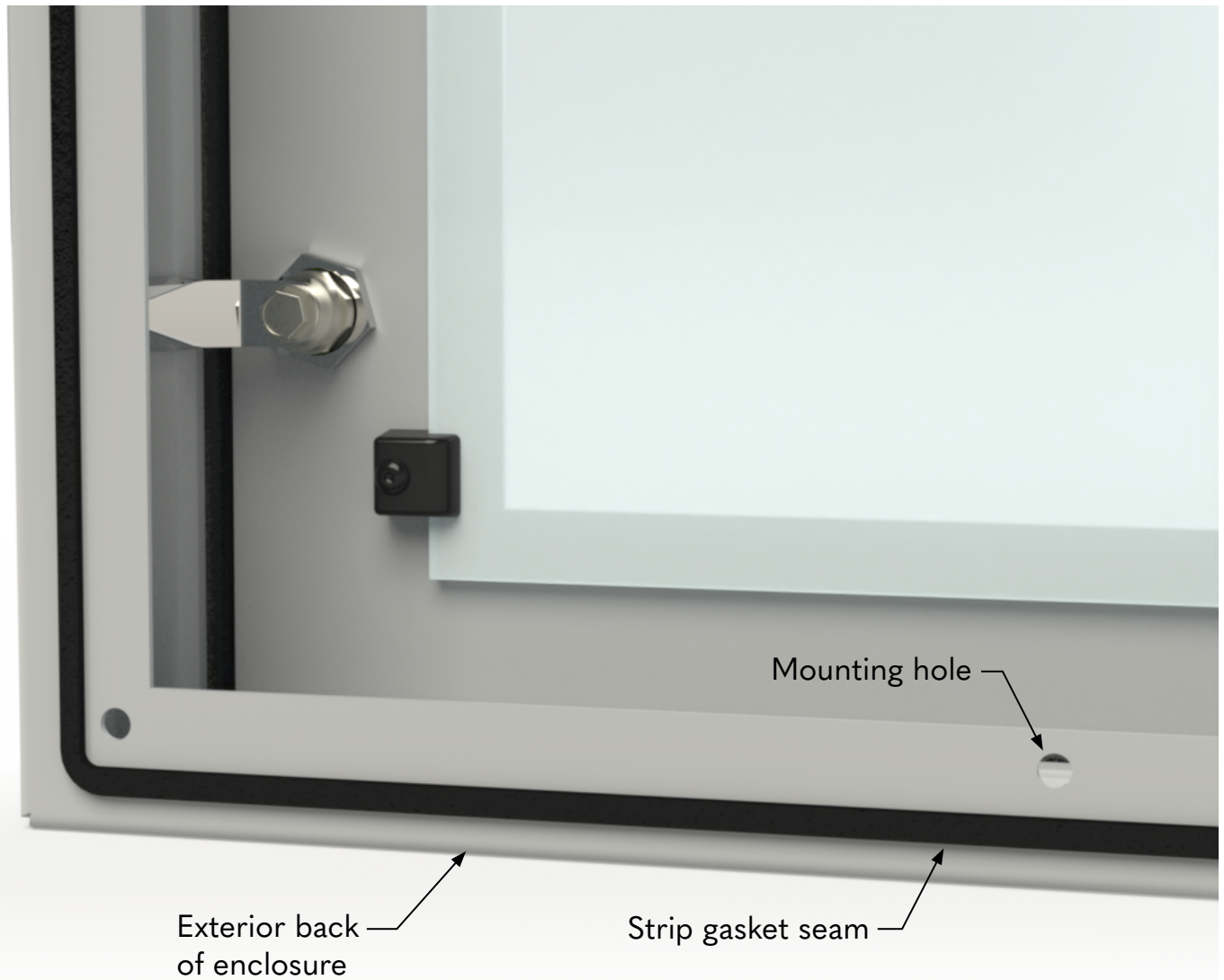

- A. Apply strip gasket provided with bolt pack to the exterior back of the enclosure.
- B. Start applying the strip gasket centered at the bottom of the enclosure.
- C. The strip gasket needs to be applied in one continuous path, on the outside of each mounting hole.
- D. End with the strip gasket seam centered at bottom of the enclosure, flush to the starting point.



*Your Enclosure Source*®