

# DEAD FRONT, TWO DOOR DISCONNECT

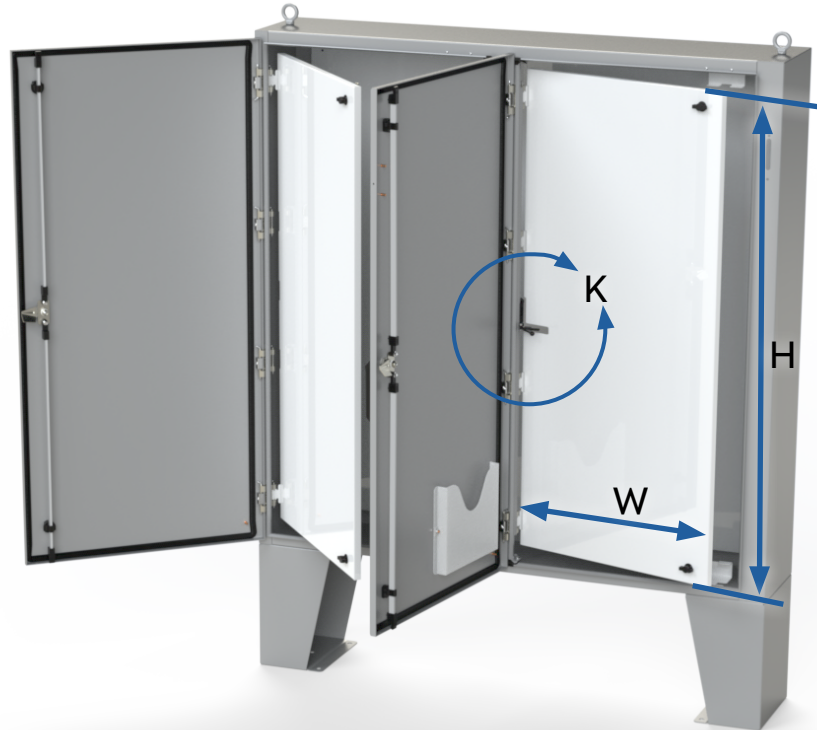

Front Isometric View  
doors and dead fronts open

**Dead front panel size:**  
 H = Enclosure door opening - 2.50"  
 W = Enclosure door opening - 1.00"

**Bolt pack:**  
 132000 for 3 hinge dead fronts  
 131982 for 4 hinge dead fronts

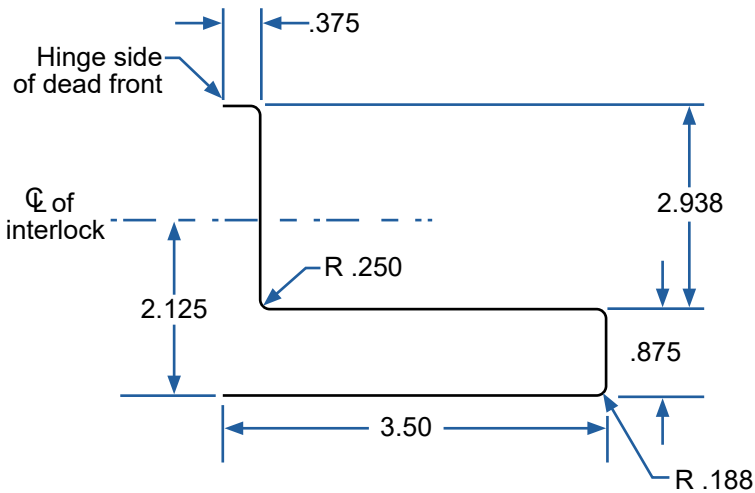

**"K" Detail (Not to scale)**  
 Mechanical interlock arm clearance cutout required on the hinge side of dead front.  
 Cutout required only when new plastic interlock is used.

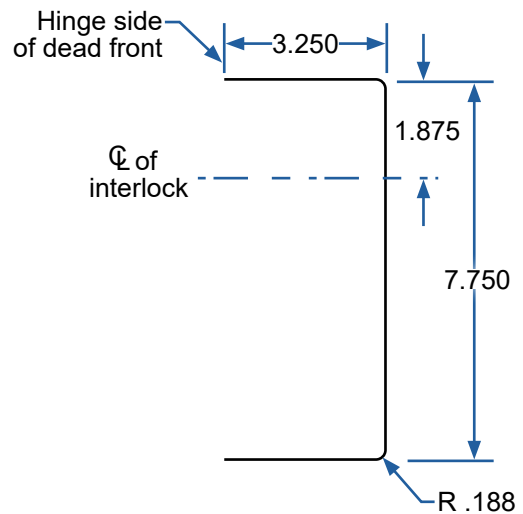

**"K" Detail (Not to scale)**  
 Mechanical interlock arm clearance cutout required on the hinge side of dead front.  
 Cutout required only when old metal interlock is used.

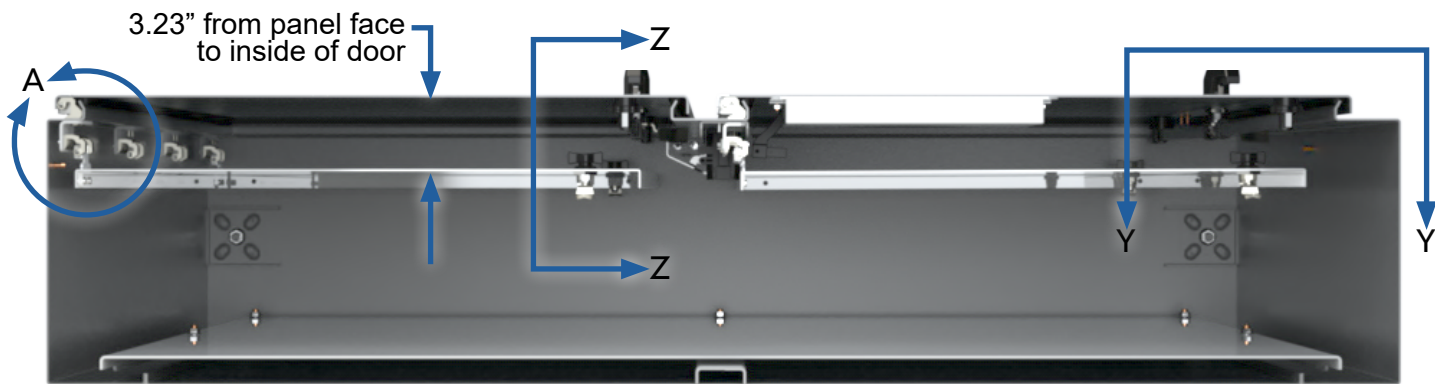

Bottom View  
with bottom removed

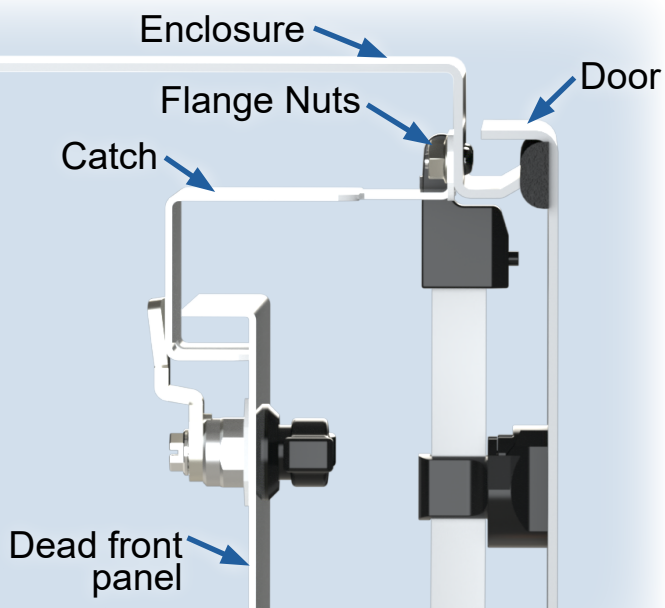

Section Z-Z

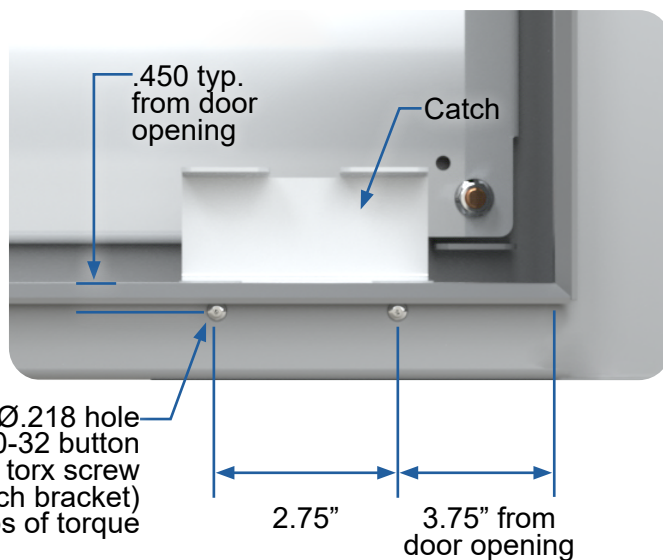

Section Y-Y

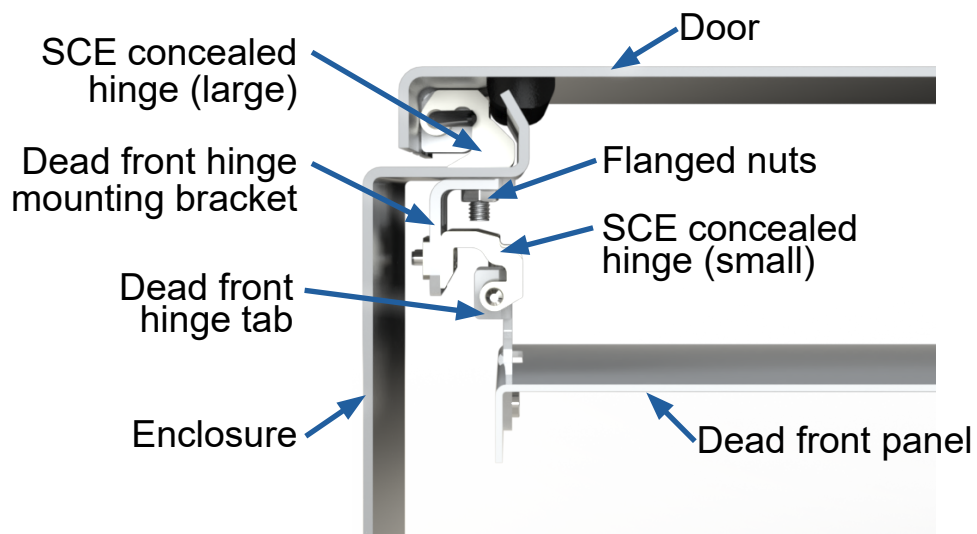

Detail A